

Bowl feeder

WV401-1 / 402-1



Translation of operating and installation instructions

Copyright by Afag GmbH



This operation instruction applies to:

Type			Order number
Bowl feeder WV401-1	230 V / 50 Hz	Right	50177366
		Left	50177365
	115 V / 60 Hz	Right	50177373
		Left	50177372
Bowl feeder WV402-1	230 V / 50 Hz	Right	50103719
		Left	50103718
	115 V / 60 Hz	Right	50177371
		Left	50177368

Version of Documentation:

BA_WV400_R04.2_EN.docx

Release:

R04.2

Date:

07/01/2021

Table of contents:



1	Safety instructions	4
1.1	<i>Notes on symbols and instructions</i>	4
1.2	<i>General safety instructions</i>	5
1.3	<i>Intended purpose</i>	5
1.4	<i>Notes for Pacemakers and Defibrillators</i>	6
2	Description of the device	7
2.1	<i>General</i>	7
2.2	<i>Functional description</i>	7
2.3	<i>Definition of direction of rotation</i>	8
2.4	<i>Technical data</i>	9
3	Assembly instructions	11
3.1	<i>Transport</i>	11
3.2	<i>Mounting the unit.....</i>	11
3.3	<i>Fixing the bowl.....</i>	12
3.3.1	<i>Bowl attachment at drive system</i>	12
3.4	<i>Power supply</i>	14
4	Operating instructions	15
4.1	<i>Standard operation.....</i>	15
4.2	<i>Device specific adjustment</i>	15
4.2.1	<i>Feed rate decreases</i>	16
4.2.2	<i>Feed rate increases</i>	16
4.3	<i>Torques</i>	17
5	Maintenance instructions	18
5.1	<i>Leaf spring removal</i>	18
5.2	<i>Magnet gap adjustment.....</i>	19
5.3	<i>Wear and spare parts</i>	20
6	Accessories	20
6.1	<i>Mounting parts.....</i>	20
6.2	<i>Adjustment aids.....</i>	20
6.3	<i>Controller.....</i>	21
6.4	<i>Address for orders.....</i>	22
7	Disposal	22



1 Safety instructions



1.1 Notes on symbols and instructions

Symbols: Assembly and commissioning must be carried out by qualified personnel only and according to these operating instructions.

Please observe the meaning of the following symbols and notes. They are grouped into risk levels and classified according to ISO 3864-2.

 DANGER	
	Indicates an immediate threatening danger. Non-compliance with this information can result in death or serious personal injuries (invalidity).

 WARNING	
	Indicates a possible dangerous situation. Non-compliance with this information can result in death or serious personal injuries (invalidity).

 CAUTION	
	Indicates a possibly dangerous situation. Non-compliance with this information can result in damage to property or light to medium personal injuries.

NOTE	
	Indicates general notes, useful operator tips and operating recommendations which don't affect safety and health of the personnel.



1.2 General safety instructions

These operating instructions are intended as a basis for safe utilisation and operation of the Bowl Feeder Type WV. All persons working with or on the Bowl Feeder are required to follow the operating instructions, particularly the safety instructions. Any additional rules or regulations for the prevention of accidents that may be applicable at the location of use also have to be observed.

The operating instructions have to be stored at the location where the Bowl Feeder is used.

1.3 Intended purpose

Afag Bowl Feeder Type WV devices are exclusively intended for bunkering, conveying, isolating and sorting items of different dimension, shape and material. Appropriate use also includes observation of all Notes in these operating instructions.

 WARNING	
	<p>The KLF may not be used:</p> <ul style="list-style-type: none"> in damply and wet area in temperature lower than 10°C or higher than 45°C in areas where readily flammable media are present in areas where readily explosive media are present in heavy polluted or dust- laden area in aggressive area (e.g. saliferous atmosphere)

None modification or reconstruction are allowed. The operations described in chapter 3.3 Fixing the bowl and in chapter 4 Operating instructions are excluded from this arrangement.

NOTE	
	<p>Deviating utilization is considered to be improper and leads to expiration of any warranty claims.</p>

Please also refer to our General Terms of Business in this respect.

1.4 Notes for Pacemakers and Defibrillators

Afag vibration conveyors are tested in accordance with regulation 15 of the German Statutory Accident Insurance Association [Deutsche Gesetzliche Unfallversicherung, DGUV] (previously BGV B11 of German Accident Prevention Regulations). The permissible values of exposure area 2 are not exceeded, therefore no measures are required pursuant to Section 4 (2) of the DGUV regulation 15. The definitions of Section 12 "Indirect Effects, Medical Implants" remain unaffected by the above.

The alternating magnetic fields that occur in the immediate vicinity of certain vibration conveyors may affect the proper functions of active implants, i.e. pacemakers and defibrillators. Anyone with active medical implants, for which no individual risk assessment has been provided, must observe the specified safety distances to the vibration conveyors. The distances each relate to the position of the upper body and the active medical implant relative to the field source.

Type	Safety Distance
WV401-1 / WV402-1	15cm around, 20cm above

2 Description of the device

2.1 General

The Bowl Feeder is used in association with a bowl for bunkering, conveying, isolating and sorting bulk material. Transport is achieved by vibration. Parts are moved in the feed direction by means of a small-scale throwing action (micro-throws).

The weight of the bowl used should not exceed the value specified in Section 2.4 to ensure optimal conveyance.

NOTE



Bowl Feeders should be operated in combination with an Afag control device. Optimal conveyance can only be guaranteed for such combination.

2.2 Functional description

A vibratory feeder is a device that transforms electromagnetic oscillations in order to use them for transporting parts.

A Bowl Feeder is basically made up of the following elements (see Figure 1):

- A Feeding bowl
- B Feed material
- C Spring assembly
- D Drive magnet
- E Armature
- F Counterweight
- G Rubber damper

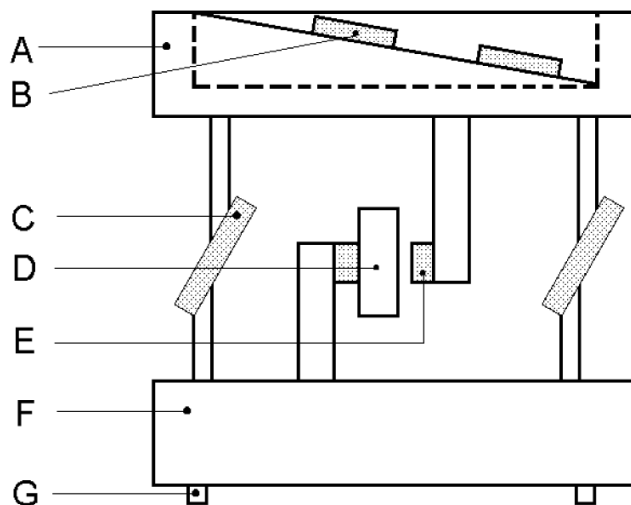

Figure 1: Sketch of the principle underlying a Bowl Feeder drive

The drive magnet (**D**), connected to a counterweight (**F**), generates a force that attracts and releases the armature (**E**) depending on the frequency of the power supply system.

Since the armature (**E**) is connected to the feeding bowl (**A**), this also moves at the same frequency. Depending on the inclination of the leaf spring, the feed material is projected above the feeder belt at each oscillation, which leads to a small-scale throwing action (micro-throw) perpendicular to the plane of the spring leaf.

With an alternating current of 50Hz, the Bowl Feeder carries out 100 oscillations per second, since the oscillating magnet attracts the magnet armature during positive as well as negative current pulses. This oscillation of 100Hz is necessary in order to achieve regular and gentle transportation of small or light parts.

An oscillating frequency of 50Hz is however required for larger or heavier parts. A half wave of the sinus wave is cut off for this.

2.3 Definition of direction of rotation

The direction of rotation of the Bowl Feeder is defined as follows:

Left (L), is an **anti-clockwise direction**

Right (R), is a **clockwise direction**

Figure 2: Definition of the direction of rotation

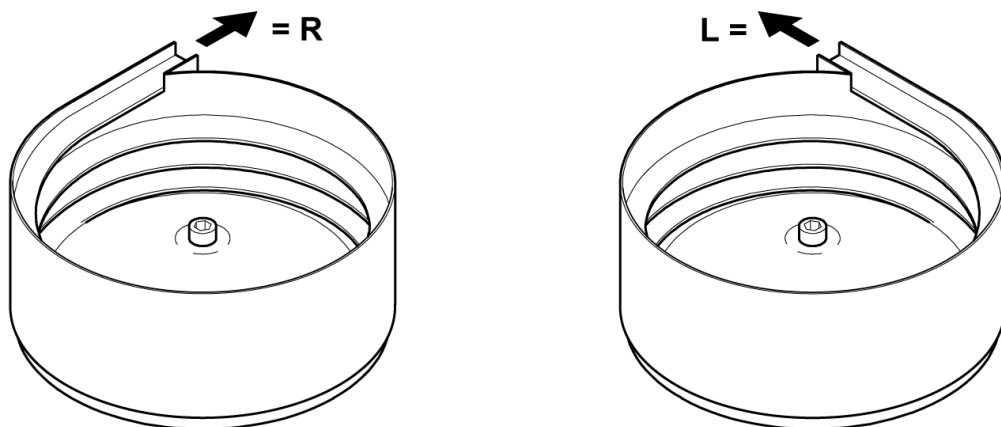

2.4 Technical data

Figure 3: Dimensional sheet WV401/ WV402

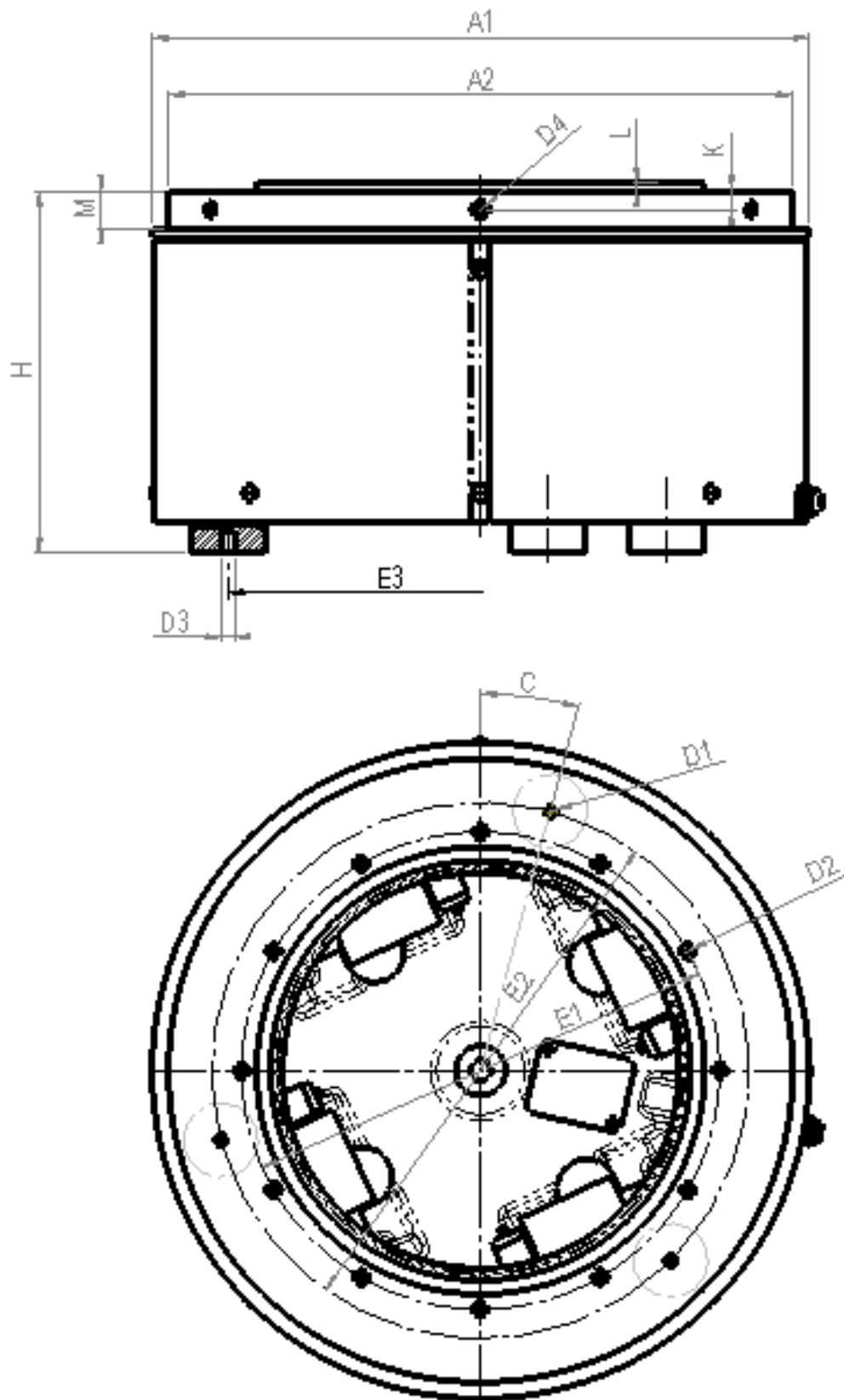

Table 1: Technical Data

Type		Units	WV 401-1	WV 402-1
Dimension	A	[mm]	440	
	A2	[mm]	418	
	C	[°]	15	
	D1	-	3x Ø8H7	
	D2	-	12 x M6	
	D3	-	3 x M10	
	D4	-	6 x M8	
	E1	[mm]	320	
	E2	[mm]	360	
	E3	[mm]	350	
	H	[mm]	243	
	K	[mm]	12,5	
	L	[mm]	5	
	M	[mm]	25	
Permitted bowl weight		[kg]	35	35
Weight		[kg]	107	107
Power		[VA]	1260	1128
Protective system		IP	IP 54	
Compensation of oscillation force		-	not	
Electr. Version		[V / Hz]	230 / 50 or 115 / 60	
Oscillation frequency		[1/min]	-	6000 / 7200
Direction of rotation		[1/min]	3000 / 3600	-
Leaf spring inclination		-	right / left	
Permitted bowl weight		[°]	15	15
Environmental conditions for operation: Temperature range		[C°]	+10 to +45	
Noise emission: Continuous noise pres- sure level (without transported material)		[dB]	<70	
Measuring height/measuring distance		[m]	1,6 / 1	
Measurement direction with respect to the noise source		[°]	90	
Measurement method		-	A evaluation	

3 Assembly instructions

3.1 Transport

NOTE



The Bowl Feeder must only be lifted from the base plate during transport. A special hole in the middle of the base plate is provided for attachment of suitable aids for lifting up the Bowl Feeder.

3.2 Mounting the unit

Each Bowl Feeder is equipped with 3 vibration damper mounts with which the Bowl Feeder can be screwed on to a substructure. The substructure should have an adequate weight.

Please refer to Table 1 in Section 2.4 for the dimensions of the mounting holes.

Bowl Feeder with base plate (see Figure 4)

Bowl Feeder with base plate and mounting foot (see Figure 5)

Bowl Feeder with base plate and adjusting foot (see Figure 6)

Please make sure that the base is horizontal when mounting the Bowl Feeder.

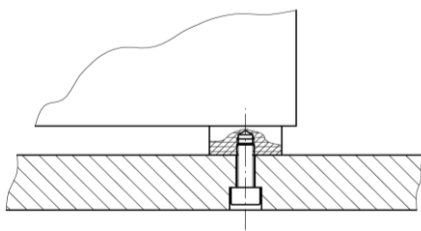

Figure 4

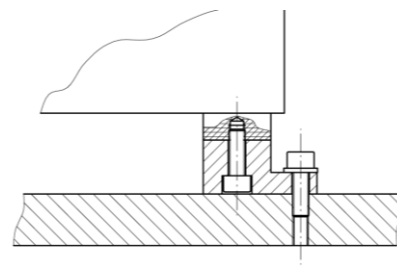

Figure 5

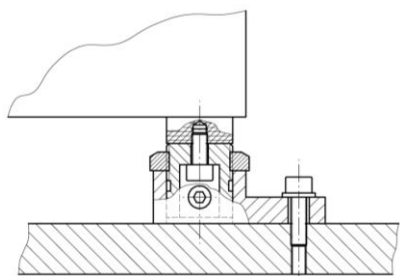

Figure 6

3.3 Fixing the bowl

The maximum permitted weight of the feeding bowl must not be exceeded in order to ensure proper function of the Bowl Feeder. Fitting holes are provided at the top of the mounting plate allowing exact positioning of the bowl to the Bowl Feeder drive system. This makes new alignment of the bowl outlet interface unnecessary when changing the bowl.

3.3.1 Bowl attachment at drive system

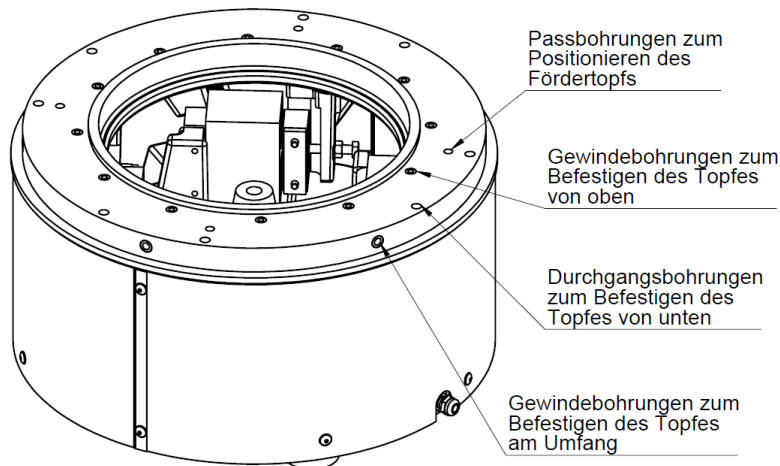
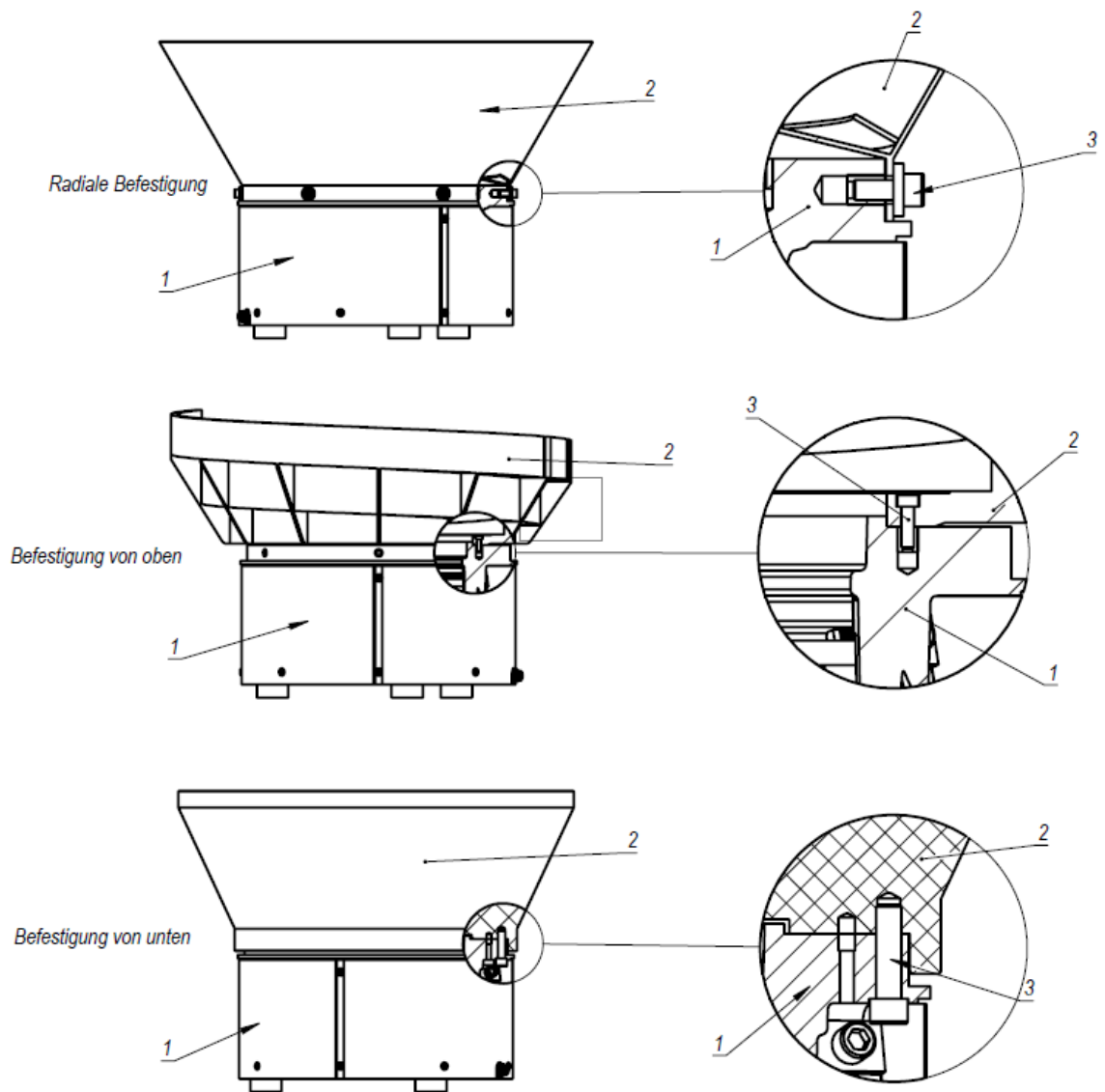



Figure 7: Bowl attachment, radial, from above and at the circumference



3.4 Power supply

 WARNING	
	<p>Any work performed on the electrical supply may only be performed by trained, authorised, qualified personnel!</p> <p>The power supply must be protected by an FI switch (provided by the customer).</p> <p>The bowl feeder may only be operated with the power supply specified on the name plate.</p>

The control device IRG1-S is used for the activation of the bowl feeder.

For the 115V devices a suitable control unit with 12A RMS load capacity must be used instead of the IRG1-S.

The MSG801 or MSG802 can also be used. Please note that an additional CEE connector plug is required for the MSG controllers (article no. 11006982)

Installation of the plug is only to be carried out by technically qualified personnel.

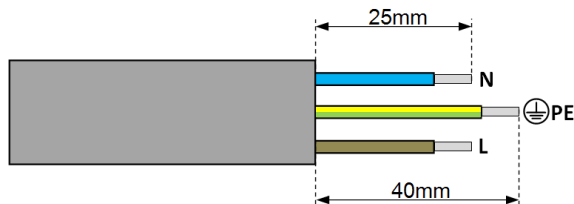

Figure 8: *End of the wire for additional plug*





4 Operating instructions

4.1 Standard operation

No further settings are required for standard operation once the control is switched on. An uninterrupted operation only requires the re-filling of the bowl.

 CAUTION	
	<p>The bulk material must be filled into the middle of the conveyor bowl. Otherwise the orientation system might be damaged or the required capacity might not be achieved as falling parts can get jammed in the orientation system.</p>

 CAUTION	
	<p>Under certain circumstances an inadmissible noise level may occur (e.g. when opening the cover of the noise protection hood for filling in parts).</p> <p>Required behaviour:</p> <p>Wear ear protection when working at critical sound levels</p>

4.2 Device specific adjustment



The Bowl Feeder is a spring/weight based vibratory system that operates by making use of resonance. This keeps energy consumption to a minimum.

The vibratory feeders are provided by the manufacturer equipped with a standard spring system. In order to achieve optimal feeding and sorting, the Bowl Feeder has to be adapted to the actual conditions of use. Adjustment is carried out by means of addition or removal of leaf springs and inserts.

The following steps are required for adjusting the Bowl Feeder:

1. Remove Bowl Feeder casing
2. Check screws for bowl attachment and leaf spring attachment for tightness (see Table 2 for tightening torques for spring attachment)
3. Check air gap of magnets (see Table 3)
4. Switch on Bowl Feeder and set controller device to 80%.

5. Slowly release the lower attachment screw from a spring assembly. Releasing the screw causes a feed rate change. Two situations may arise:
 - a. The feed rate decreases on releasing the screw. Please proceed as described in Section 4.2.1.
 - b. The feed rate increases on releasing the screw. Please proceed as described in Section 4.2.2.

 CAUTION	
	Only one spring assembly may be loosened at a time in order to prevent the mounting plate from dropping.

4.2.1 Feed rate decreases

Fit an additional leaf spring and inserts. Start with one spring at a spring assembly. If the feed rate still decreases when the attachment screw is unscrewed again, fit more leaf springs and inserts. The number of leaf springs should be distributed evenly over the spring assemblies.

4.2.2 Feed rate increases

Remove leaf springs and inserts. Start with one leaf spring. If the feed rate still increases when the attachment screw is unscrewed again, remove more leaf springs and inserts. The number of leaf springs should be distributed evenly over the spring assemblies.

The Bowl Feeder is adjusted perfectly when the desired feed rate is obtained at a control setting of 80% and the feed rate always decreases on unscrewing the attachment screw. This is also referred to as supercritical adjustment.

After adjustment of the resonant frequency, the magnet gap has to be checked. This may be changed slightly during the process of fitting/removing the springs. If this is the case, the magnet gap has to be readjusted according to Section 5.2 Magnet gap adjustment.

4.3 Torques

Tightening torques M_{Sp} in Nm for shank screws with metric ISO control threads and head supports according to DIN 912 or DIN 931:

Screw	Tightening torques M_{Sp} in Nm		
	Strength class 8.8	Strength class 10.9	Strength class 12.9
M4	2,8	4,1	4,8
M5	5,5	8,1	9,5
M6	9,5	14,0	16,5
(M7)	15,5	23,0	27,0
M8	23,0	34,0	40,0
M10	46,0	68,0	79,0
M12	79,0	117,0	135,0
M14	125,0	185,0	215,0
M16	195,0	280,0	330,0
M18	280,0	390,0	460,0
M20	390,0	560,0	650,0
M22	530,0	750,0	880,0
M24	670,0	960,0	1120,0
M27	1000,0	1400,0	1650,0
M30	1350,0	1900,0	2250,0

by: Dubbel (18th edition), page G175

5 Maintenance instructions

A Bowl Feeder type WV is generally maintenance free. The leaf springs have to be removed and cleaned only if they have become very dirty. Complete replacement of leaf springs is rarely necessary.

5.1 Leaf spring removal

Only one spring assembly may be loosened at a time when removing leaf springs in order to prevent the mounting plate from dropping or moving out of place.

⚠ CAUTION	
	<p>The leaf springs may not be lubricated with oil or grease, since this will make the springs sticky, which has a negative effect on oscillation.</p>

The number of leaf springs in a spring assembly, as well as the spring assembly structure has to correspond to that of the original spring assembly when fitted. This is necessary to ensure the function of the device.

Figure 9: Spring assembly

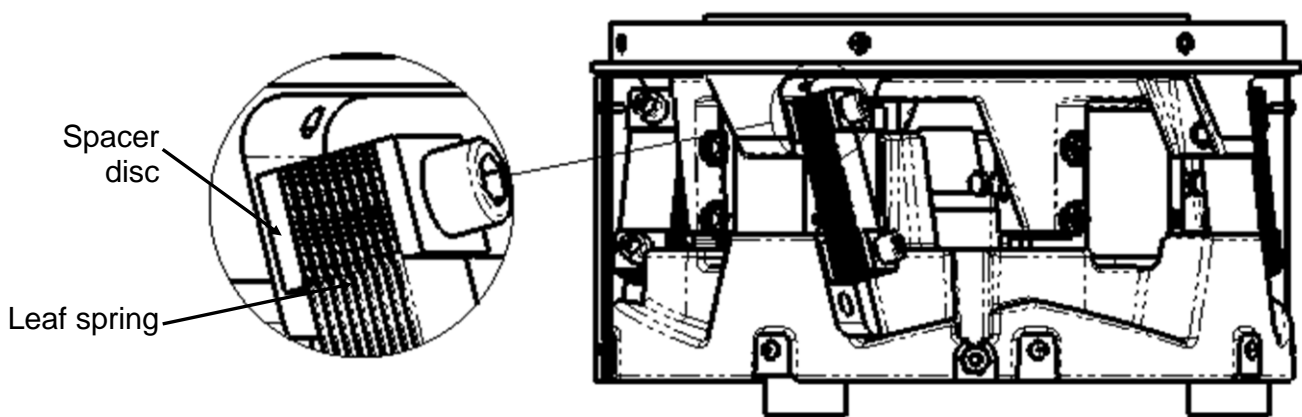

The screws have to be tightened with the appropriate tightening torque specified in Table 2. The spacer discs should not be displaced when tightening the screws.

Table 2: Tightening torques for spring attachment

Typ	WV401-1	WV402-1
Torque specification	135 Nm	135 Nm

5.2 Magnet gap adjustment

In order to readjust the magnet gap of the oscillating magnets, the casing has to be removed and the attachment screws (see Figure 10) of the magnet armatures as well as the positioning screws have to be unscrewed. An appropriate distance gauge (Table 7: Adjustment aids) then has to be inserted between the magnet armature and the magnet core. The magnet armature can then be pushed against the distance gauge and the magnet core by hand and the attachment screws can be retightened. The attachment screws have to be tightened with the appropriate turning moments (Table 3: Magnet gap and torque specification). Once all magnet armatures are fixed again, the positioning screws are screwed back in the magnet armature and secured with hexagonal nuts. It should be possible to remove the distance gauge easily but the clearance should not be excessive, since the magnet gap would then be too large. This would require repetition of the magnet gap adjustment procedure.

Figure 10: Magnet gap adjustment with distance gauges

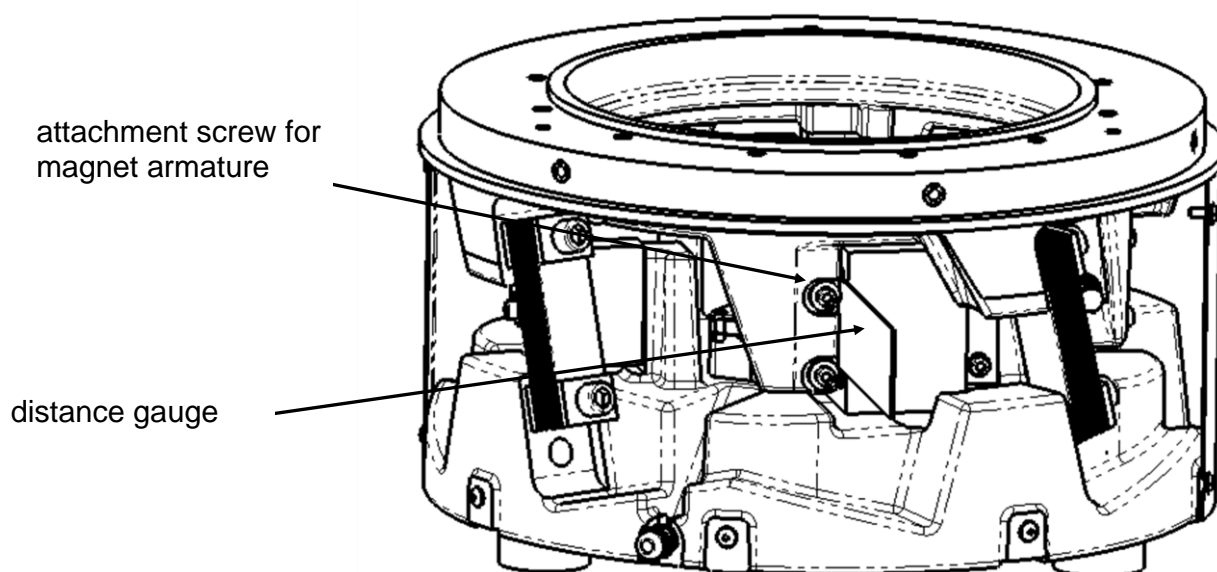

Table 3: Magnet gap and torque specification

Type	Units	WV 401-1	WV 402-1
Magnet gap	[mm]	2,0	1,5
Torque specification	[Nm]	9,5	9,5

5.3 Wear and spare parts

Table 4: *Wear parts*

Type	Designation	Order number
WV401-1	Leaf spring 2 mm	50201924
WV402-1	Leaf spring 1 mm	50111450
WV401-1	Rubber buffer B	50177631
WV402-1		

Table 5: *Spare parts*

Type	Designation	Power supply	Order number
WV401-1	Magnet	230V / 50Hz	15211762
		115V / 60Hz	15018561
WV402-1	Magnet	230V / 50Hz	15031196
		115V / 60Hz	15160938

6 Accessories

6.1 Mounting parts

Table 6: *Order data*

Type	Designation	Order number
Centring bracket		50197375
Spacer	5 mm	50021483
	10 mm	50021486
	20 mm	50021484

6.2 Adjustment aids

Table 7: *Adjustment aids*

Designation	Drive Type	Order number
Distance gauges	WV 401-1	50201935
	WV 402-1	50201938

6.3 Controller

The WV is connected to the 230V/50Hz AC system via an IRG or MSG controller and can be rated for other mains voltages and frequencies, e.g. 115V/60Hz. They operate in full-wave mode at double mains frequency, i.e. at 50Hz AC, with a vibration frequency of 100Hz, in half-wave mode at single mains frequency with a vibration frequency of 50Hz.

Vibration displacement and thus the transport speeds are infinitely adjustable due to magnet current and thus magnetic force variability.

Soft-starting, all IRG and MSG types can be mounted in various different ways and offer extra controls for photoelectric barriers, initiator elements, or extern 24VDC signal. For a detailed description of the controllers refer full-range catalogue from AFAG GmbH.

Third-party controllers can also be used as long as they meet the technical requirements.

Table 8: *Controllers for WV- Bowl feeder*

Type	Power supply	Order number	Comments
IRG1-S	230V/50Hz	50360105	Control with no timer function
	-	-	External target value preset
MSG801	230V/50Hz – 115V/60Hz	50391818	With timer function, valve and interface outputs, sensor feed
MSG802	230V/50Hz – 115V/60Hz	50391819	With sensor feed

6.4 Address for orders

Germany:

Afag GmbH

Wernher-von-Braun-Straße 1

D – 92224 Amberg

Tel.: ++49 (0) 96 21 / 65 0 27-0

Fax: ++49 (0) 96 21 / 65 0 27-490

Sales

sales@afag.com

www.afag.com

Switzerland:

Afag Automation AG

Luzernstrasse 32

CH – 6144 Zell

Tel.: ++41 (0) 62 / 959 86 86

Fax: ++41 (0) 62 / 959 87 87

7 Disposal

WF feeders that are no longer in use should not be disposed of as complete units but dismantled into separate materials and recycled. Non-recyclable components must be disposed of correctly.