

Linear feeder LF11 / LF9

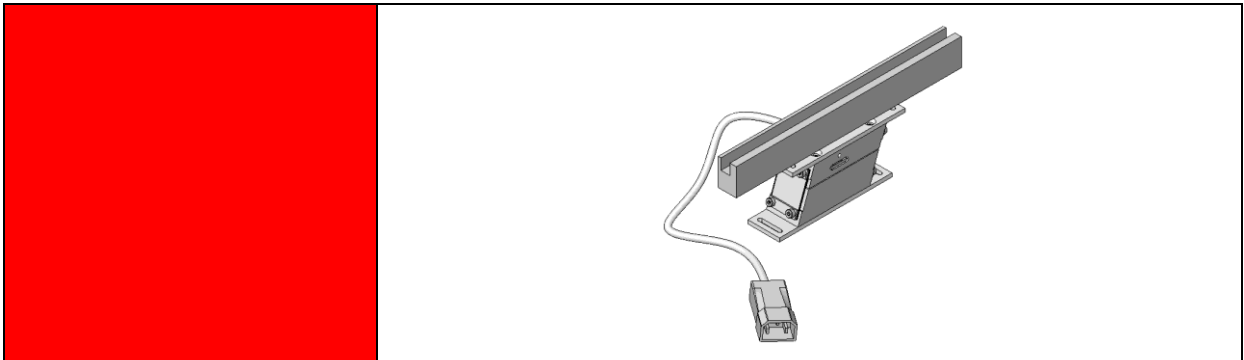

Translation of original operating instruction

Copyright by Afag GmbH

This operation instruction applies to:

Type		Order number
Linear feeder	LF11	230 V / 50 Hz 11005757
Linear feeder	LF9	230 V / 50 Hz 15105783
		115 V / 60 Hz 15068632

Version of Documentation: BA_LF9-11_R3_E.docx
Release: 3.0
Date: 2009-12-23

Table of contents

1	Declaration of incorporation for the incomplete machine.....	4
2	Safety instructions	5
2.1	<i>Explanation of symbols and notes</i>	5
2.2	<i>Basic safety information</i>	6
2.3	<i>Intended use</i>	6
3	Description of the LF linear feeder.....	7
3.1	<i>General</i>	7
3.2	<i>Functional description.....</i>	7
3.3	<i>Technical data.....</i>	9
4	Assembly instructions	11
4.1	<i>Transport</i>	11
4.2	<i>Installing the unit.....</i>	11
4.3	<i>Mounting of the linear track.....</i>	12
4.4	<i>Power supply.....</i>	13
5	Operating instructions	14
5.1	<i>Correlations between the transport speed and the LF spring package</i>	14
5.2	<i>Setting the distance between the rail and the support surface</i>	15
5.3	<i>Standard operation.....</i>	15
6	Maintenance instructions	16
6.1	<i>Troubleshooting and fault repair.....</i>	16
6.2	<i>Replacing springs or spring packages.....</i>	18
6.3	<i>Replacing the magnetic coil.....</i>	20
6.4	<i>Setting the air gap between magnetic coil and anchor bolt.....</i>	22
6.5	<i>Spare and wearing parts.....</i>	23
7	Accessories	24
7.1	<i>Mounting parts.....</i>	24
7.2	<i>Control device</i>	24
7.3	<i>Address for orders.....</i>	25
8	Disposal	25

1 Declaration of incorporation for the incomplete machine

Declaration of incorporation in compliance with the European Machinery Directive 2006/42/EC, Annex II B

The manufacturer: Afag GmbH, Wernher-von-Braun-Strasse 5a, D-92224 Amberg
www.afag.com – Phone: +49 (0)9621 650 27-0

herewith declares, that the incomplete machine: **Linear feeder LF**

Designation: **LF 9 / LF 11**

complies with the basic safety and health requirements of the Machinery Directive **2006/42/EC Annex I**.

The incomplete machine also complies with the following:

Relevant EC Directives:

Machinery Directive 2006/42/EC

Low Voltage Directive 2006/95/EC

EMC Directive 2004/108/EC

Applied harmonised standards:

EN ISO 12100-1; EN ISO 12100-2

The technical documentation for this incomplete machine was prepared in accordance with Annex VII, Part B. Upon request, the manufacturer undertakes to transmit these technical documents electronically to national authorities, if requested.

Authorised representative for the compilation of the instruction manual:

Edbauer Franz
Development Manager ZTK
Afag GmbH

The start-up of the incomplete machine is prohibited until installed in a complete machine that complies with the regulations of the EC Machinery Directive and until the EC Declaration of Conformity according to Annex II A is available.

City - Date: Company: Afag GmbH

Amberg, 23 Dec. 2009 Last name / first name
Mr. Klaus Bott

Managing Director
Afag GmbH

2 Safety instructions



2.1 Explanation of symbols and notes

Symbols: Assembly and commissioning must be carried out by qualified personnel only and according to these operating instructions.

Please observe the meaning of the following symbols and notes. They are grouped into risk levels and classified according to ISO 3864-2.

 DANGER	
	<p>Indicates an immediate threatening danger.</p> <p>Non-compliance with this information can result in death or serious personal injuries (invalidity).</p>

 WARNING	
	<p>Indicates a possible dangerous situation.</p> <p>Non-compliance with this information can result in death or serious personal injuries (invalidity).</p>

 CAUTION	
	<p>Indicates a possibly dangerous situation.</p> <p>Non-compliance with this information can result in damage to property or light to medium personal injuries.</p>

NOTE	
	<p>Indicates general notes, useful operator tips and operating recommendations which don't affect safety and health of the personnel.</p>

2.2 Basic safety information

This operating manual provides the basis for the safe use and operation of the linear feeder. This operating manual and, in particular, the included safety instructions have to be observed by all individuals working with and on the linear feeder. In addition, all rules and regulations regarding the accident prevention applicable for the site of operation are to be complied with.

The operating manual must always be kept at the site of operation of the linear feeder.

2.3 Intended use

The linear feeder is intended to convey component parts of different sizes, designs and types of material.

The workpieces must meet the following requirements in order to ensure a problem-free operation:

- they must be free of oil, grease and burrs
- they must not be sticky
- they must not be statically charged
- they must not be magnetic (no self-magnetism)
- they must be free of dirt and not be mixed with foreign parts
- rubber parts can be powdered with talcum

3 Description of the LF linear feeder

3.1 General

The LF, together with a transport rail, is designed for feeding bulk materials.

The LF must only be used in combination with the corresponding Afag controller. This combination guarantees optimum transport behaviour.

The LF must be fixed onto a sufficiently solid support, in order to avoid the conduction of vibrations to other parts

3.2 Functional description

The LF is a unit which transforms electromagnetic oscillations in order to use them to feed component.

The basic construction of the LF contains the following elements: (see Figure 1):

- 1 Material to be conveyed
- 2 Feeder rail
- 3 Leaf springs
- 4 Jumping-off direction
- α Jumping-off angle
- β Inclination of leaf spring

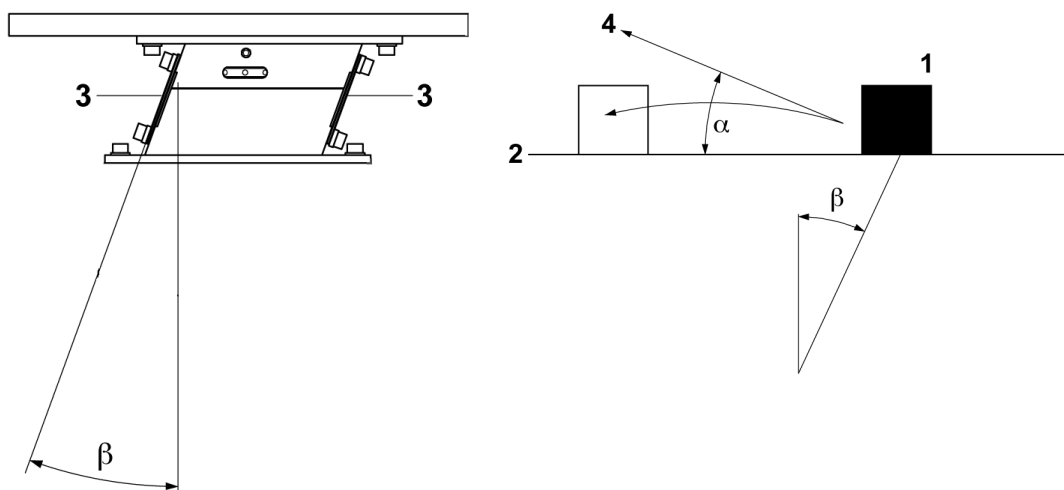

Figure 1

The magnet, connected to the support, creates a force which attracts and releases the oscillating plate dependent on the oscillation frequency of the power supply.

The pulsating movement of the oscillation plate causes the material to jump from the rail at each oscillation and is conveyed as a result of the angle of inclination of the leaf springs.

On a cycle of the 50Hz alternating current supply, the magnet achieves twice its maximum pulling force while this is independent of the direction of current flow. The magnet thereby produces an oscillating frequency of 100 Hz. This 100 Hz oscillation is necessary to achieve a smooth or gentle transport.

With heavy or large work pieces however, it is necessary to use an oscillating frequency of 50 Hz. A half wave of the mains supply is thereby blocked.

3.3 Technical data

Dimensions LF11

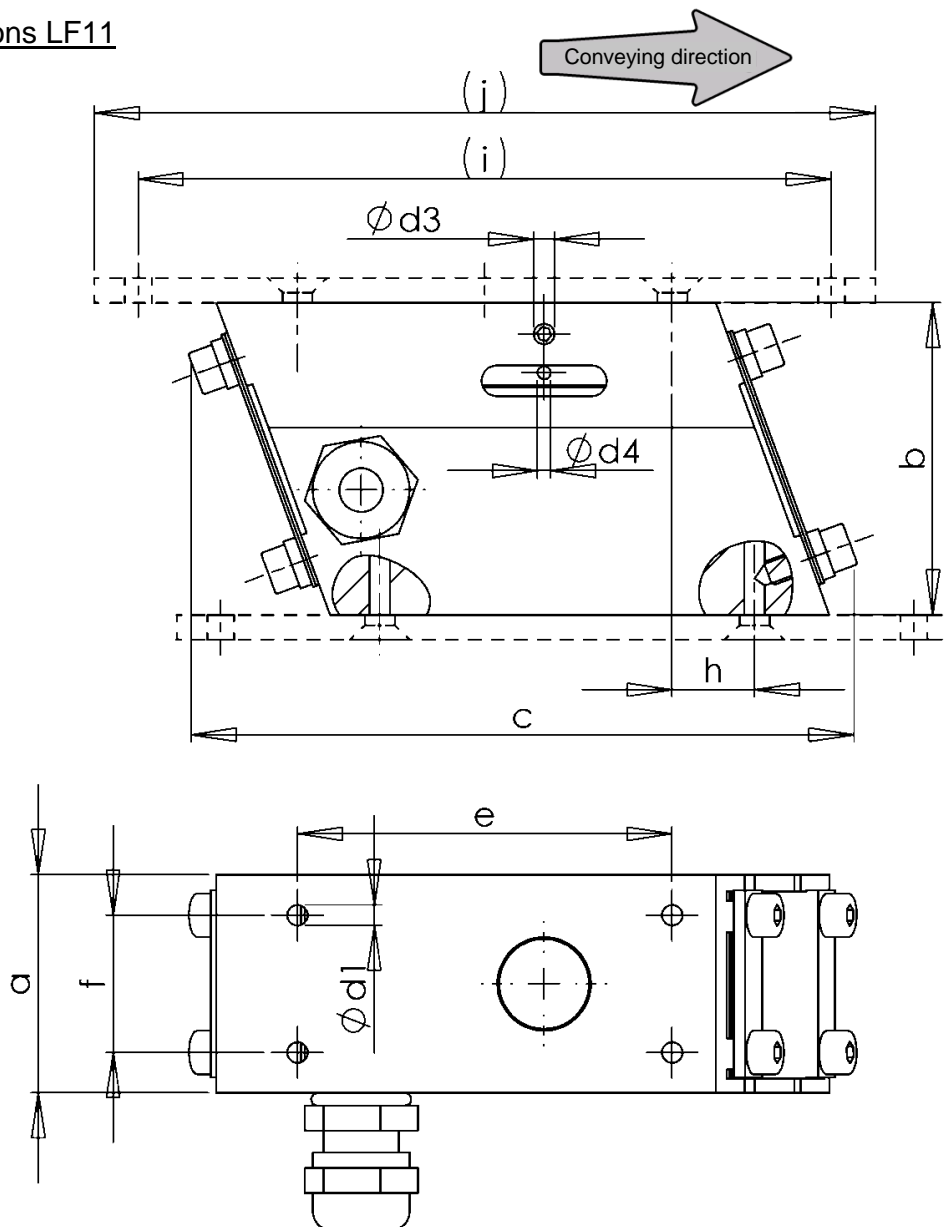

Figure 2

Dimensions LF9:

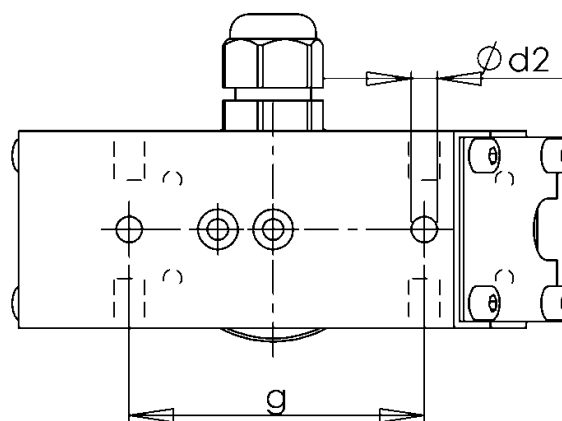

Figure 3



Table 1: Technical data

Description		Units	LF11	LF9
Dimensions	a	[mm]	35	32
	b	[mm]	50	39
	c	[mm]	106,15	89
	d1	-	M4	M4
	d2	-	-	M5
	d3	[mm]	3,3	-
	d4	[mm]	2,1	-
	e	[mm]	60	54
	f	[mm]	22	16
	g	[mm]	-	48
	h	[mm]	13,2	7
	(i)	[mm]	115	88
(j)	[mm]	125	100	
Operating voltage		[VAC]	230	230 / 115
Mains frequency		[Hz]	50	50 / 60
Degree of protection		[IP]	54	
Vibration frequency (full wave)		[1/min]	6000	6000 / 7200
Vibration frequency (half wave)		[1/min]	3000	-
Weight (LF only)		[kg]	0,95	0,75
Spring thickness (standard)		[mm]	0,5	0,7
Air gap (Magnetic coil-anchor bolt)		[mm]	0,2-0,4	
Magnet performance		[VA]	2	0,8
Environmental conditions for operation: Temperature range		[°C]	-10 to +45	
Noise emission: Continuous noise pressure level (without transported material)		[dB]	<70	
Measuring height/measuring distance		[m]	1,6 / 1	
Measurement direction with respect to the noise source		[°]	90	
Measurement method		-	A evaluation	

4 Assembly instructions

4.1 Transport

 WARNING	
	<p>Improper use of transport means (industrial trucks, cranes, technical aids, sling gear etc.) may lead to bruises and other injuries. Required behaviour:</p> <ul style="list-style-type: none"> - Observe and follow the transport and maintenance instructions - Proper use of transport means

 CAUTION	
	<p>When transporting the LF, it must be held and lifted at the support only. The transport rail is not to be held.</p>

4.2 Installing the unit

The LF is firmly screwed to the foundation using the boreholes on the bottom. 4 screws in case of the LF11 and 2 screws in case of the LF9 are affixed from below. The use of mounting plates allows the optional mounting from above. (See Chapter 7.1 Mounting parts).

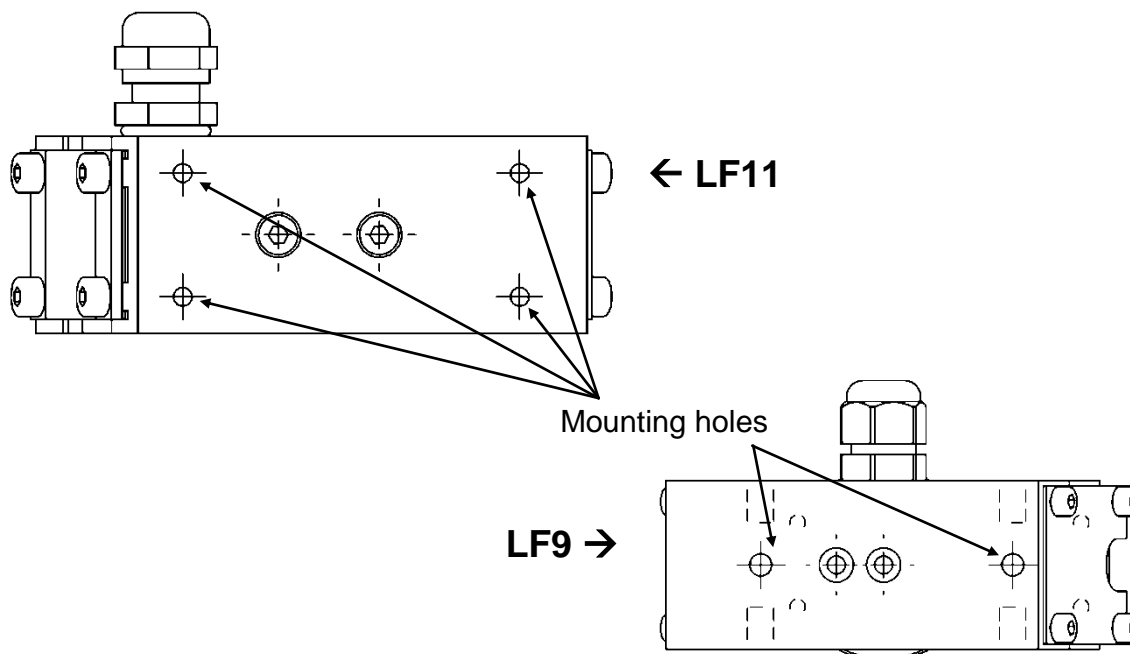

Figure 4

For the operation, the linear feeder must always be mounted on a sufficiently dimensioned (mass) subframe. The subsurface should be vibration-resistant (plate or block design) in order to absorb the vibration forces.

Self-supporting profiles must be reinforced by a base plate on which the linear feeder is attached. A steel plate should be used which is at least 20mm thick and more than 120mm wide.

Suitable substructures are to be provided for the height adjustment. Suitable afag standard parts are available for complete station extensions in combination with afag helical conveyors.

During the assembly of the linear feeder make sure that the base is horizontal or slightly inclined in the direction of transport (1.5-2°).

4.3 Mounting of the linear track



In order to achieve optimum transport speed, the following basic requirements must be fulfilled:

1. The rail and LF-support must match each other
2. The structure of the rail must transmit the vibration ideally. (rail-profile standing, not flat)
3. The length of the conveyor rail must not exceed the maximum permissible length. (see 3.3 Technical data)
4. Depending on the material to be conveyed, a maximum of two additional support springs is necessary.
5. The weight of the rail (including parts) must not exceed the weight limit. (see 3.3 Technical data)

The rail is to be aligned approximately symmetrical to the intermediate plate of the linear feeder. The conveying speed can be increased by tilting the rail in the direction of travel by 1.5 – 2°.

All LF models feature four boreholes on the upper side of the drive to connect the conveying rail to the vibratory conveyor. (See Chapter 3.3 Technical data)

4.4 Power supply

 WARNING	
	<ul style="list-style-type: none"> ▪ Any work on the electrical supply may only be performed by trained, authorised, qualified personnel! ▪ The power supply must be protected by an FI switch (provided by the customer). ▪ The helical conveyor may only be operated with the power supply specified on the name plate.

The IRG 1-N and IRG 2-N control devices can be used to activate the linear feeder. The SE 601 or SE 602 can also be used. Please note that an additional CEE connector plug is required for the SE controllers (article no. 11006982)

Installation of the plug is only to be carried out by technically qualified personnel according Figure 5.

Figure 5: End of the wire for additional plug

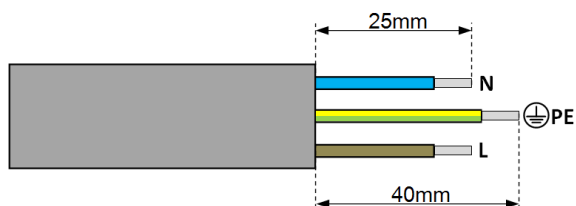

5 Operating instructions

5.1 Correlations between the transport speed and the LF spring package

(See Figure 6)

Basically the LF and the transport rail are adjusted in the standard configuration. This means that all oscillating elements are set optimally.

The following factors however influence the combination LF / transport rail:

- The parts to be conveyed (size, weight, shape, material and quality)
- The feed rate
- The support
- Surrounding (are there other oscillating components with disturbing influence or shakes from handling components)

Procedure for adjustment of the oscillating system:

 WARNING	
	Unplug the power cable, before proceeding with further actions!

1. Check the settings on the control device (see separate operating manual).
2. Check that all springs and fixing screws are tight
3. Check that the type and frequency of the magnets is correct (see chapter 3.3)
4. Check the air gap between magnetic coil and the anchor bolt (see chapter 6.4)
5. Switch on the LF and alter the transport speed with the controller regulator.
6. Depending on the transport material, additional springs have to be installed or removed (see Chapter 6.2).

5.2 Setting the distance between the rail and the support surface

This setting is only necessary when:

- All spring packages have been exchanged or re-assembled
- The LF has been dismantled

 WARNING	
	Unplug the power cable, before proceeding with further actions!

1. Loosen the screws slightly (1)
2. The distance **X** in front and at the back of the linear feeder has to be the same. Check the dimension of **X**
3. Tighten the spring package screws again (1)
4. Check the air gap between the magnetic coil and the anchor bolt and adjust if necessary (see chapter 6.4)

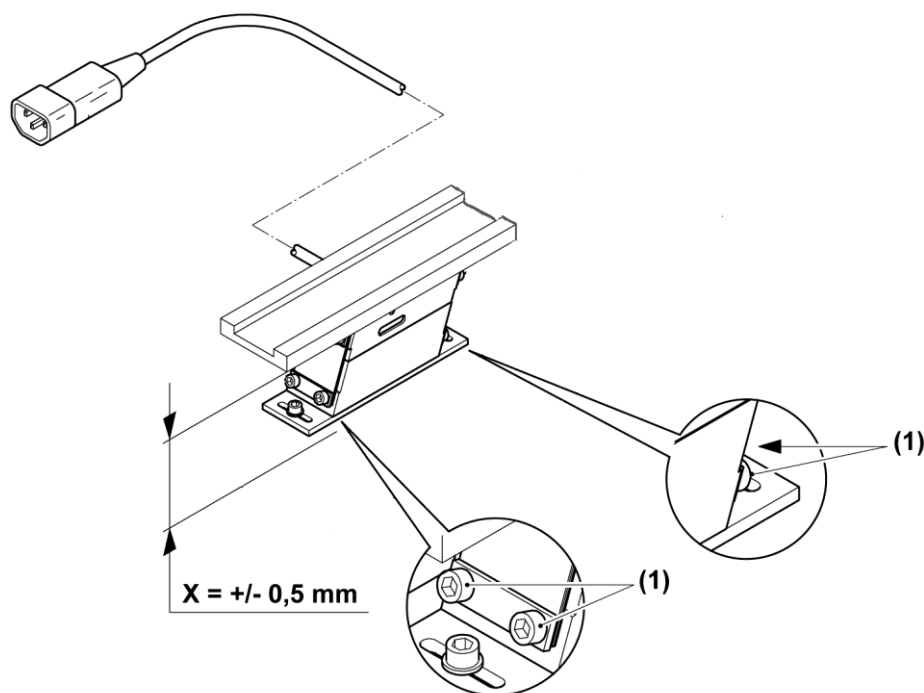

Figure 6

5.3 Standard operation

No further settings are required for standard operation mode once the controller is switched on.

6 Maintenance instructions

WARNING



The electrical equipment of the linear feeder must be checked at regular intervals. Loose connections, burnt or damaged cables are to be removed immediately!

NOTE



Check all visible screws for tightened

6.1 Troubleshooting and fault repair

WARNING



Electrical work must only be carried out by trained personnel!

WARNING



Unplug the power cable, before proceeding with further actions!

Interruptions caused by defective components must be repaired by replacing the defective component, only.

NOTE



Defective components must only be replaced by Afag original spare parts.

Linear feeder does not run after switching it on	
Cause of fault:	Fault repair
Plug not connected	Connect plug
Connecting cable between bowl feeder and controller not plugged in	Connect plug
Regulator on controller set to „0“	Turn regulator to position
Defective fuse in control unit	Replace fuse
Bowl feeder lacks performance after operating for a certain length of time	
Cause of fault:	Fault repair
The spring package fixing screws have become loose	Remove the casing and retighten all spring package screws
The air gap between the magnetic coil and the anchor bolt is no longer correct	Remove the casing and readjust the air gap (See chapter 6.4)
Spring broken	Remove the casing and replace the broken spring (See chapter 6.2)
Regulator on control unit has moved	Readjust regulator
Bowl feeder develops loud noises	
Cause of fault:	Fault repair
The magnetic coil or anchor bolt have become loose	Tighten the screws (See chapter 6.3)
Transport-speed incorrect	
Cause of fault:	Fault repair
Potentiometer defective	Replace potentiometer (See „Controller operating instructions“)

6.2 Replacing springs or spring packages

(See Figure 7)

This procedure is only necessary when:

- The oscillating behaviour of the LF has changed
- A spring is broken

WARNING



Unplug the power cable, before proceeding with further actions!

NOTE



Spring packages must contain the same leaf spring type!

The relevant spring cross section can be taken from chapter 3.3.

1. Loosen the screws (1) on the oscillation plate (2), as well as the support (3) and remove them, together with the spacers (4)
2. Remove the springs (5) and replace with a new package

NOTE



Broken springs have to be replaced with the same spring type and thickness.

3. Tighten (1) the screws.
4. Establish parallelism between the oscillation plate and the support base (see chapter 5.2)
5. Check the air gap between the magnetic coil and the anchor bolt and adjust if necessary (see chapter 6.4)
6. Carry out a test run.

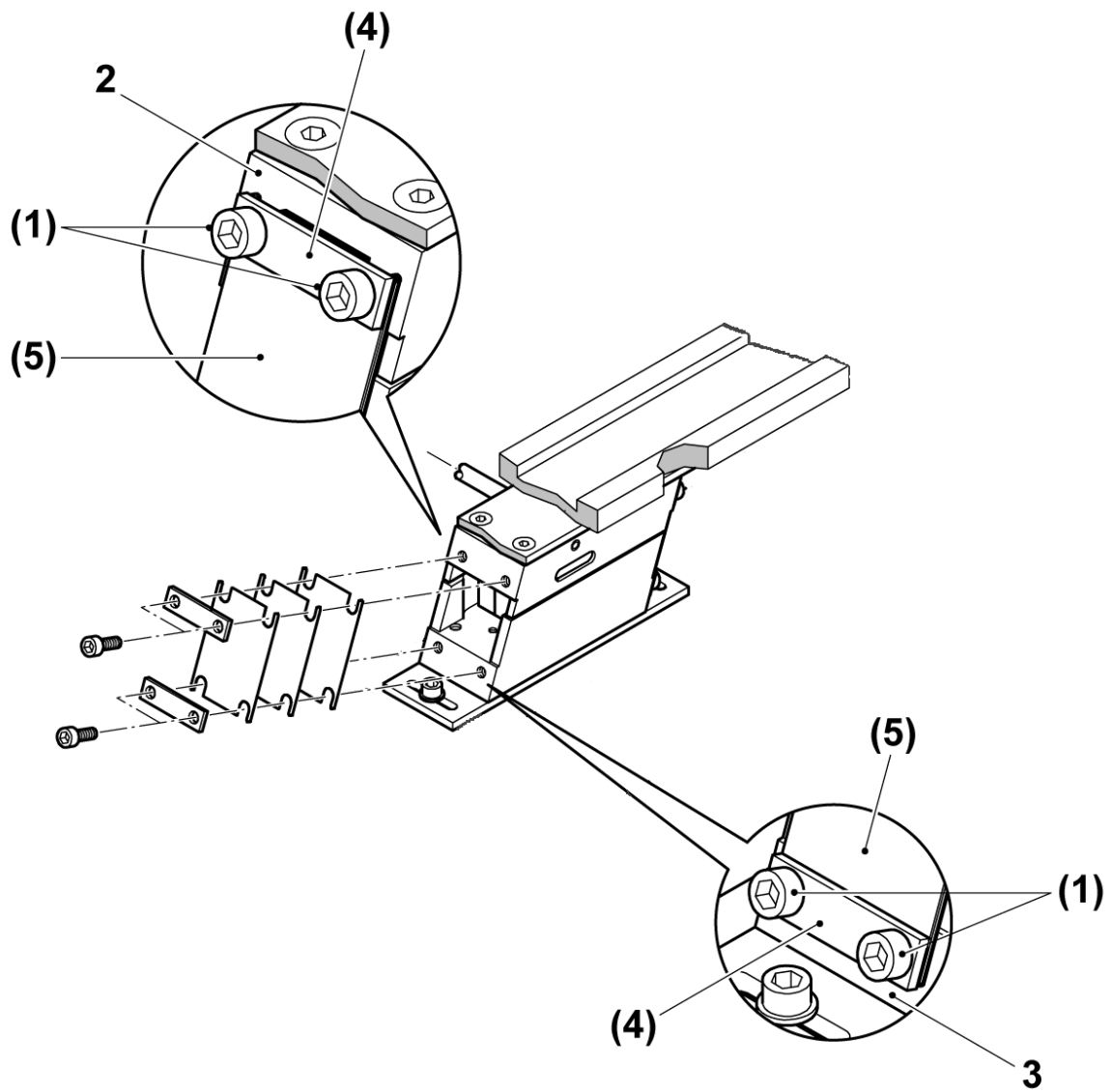

Figure 7

6.3 Replacing the magnetic coil

(See Figure 8)

This procedure is only necessary when:

- The magnetic coil is defective

 WARNING	
	Unplug the power cable, before proceeding with further actions!

1. Loosen the screws (1) on the oscillation plate (2) and remove the entire unit
2. Unplug the Euro plug from the control unit and disassemble

 WARNING	
	Electrical work must only be carried out by trained personnel!

3. Remove the screws (5) from the distance plate (6), if installed and remove the distance plate from the support base (7) by loosening the screws (8)
4. Loosen the cable clamp (9) and remove the screws (10). Remove the magnetic coil (11) and pull the cable through the cable clamp.
5. Reassemble in the reverse order.

NOTE	
	This procedure generally includes adjustment of the air gap between the magnetic coil and the anchor bolt. (See chapter 6.4).

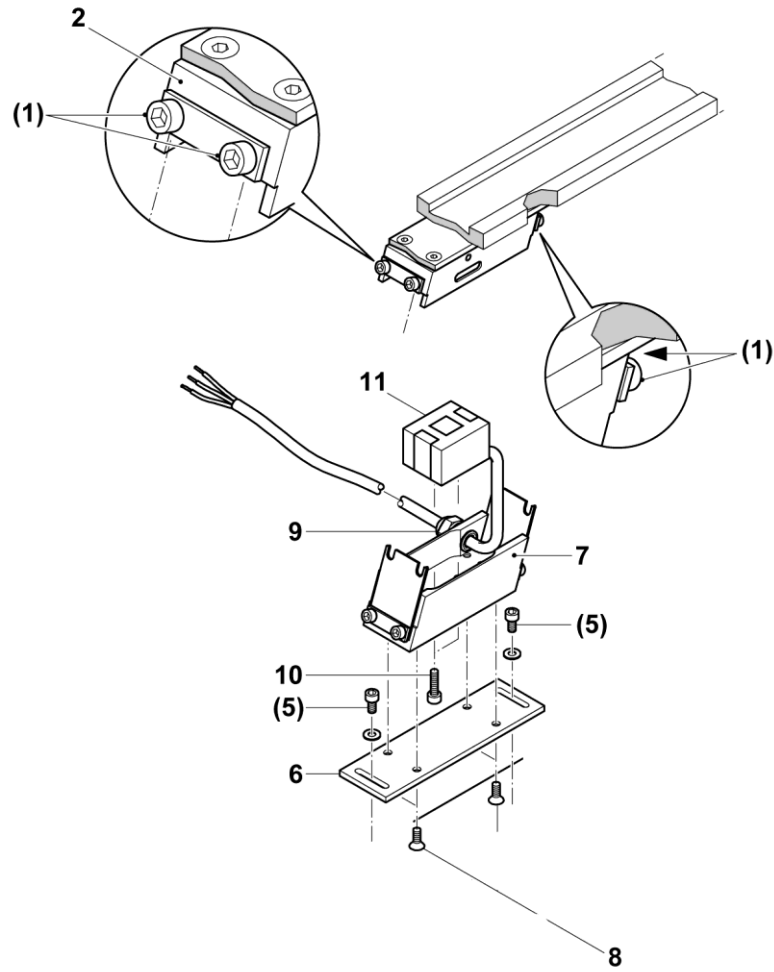

Figure 8

6.4 Setting the air gap between magnetic coil and anchor bolt

This procedure is only necessary when:

- The distance between the oscillation and the support surface has been reset
- Springs or spring packages have been exchanged
- The magnetic coil has been replaced

WARNING



Unplug the power cable, before proceeding with further actions!

NOTE



Before setting the air gap, check the parallelism (1mm) and the distance between the oscillation plate and the support.

1. Turn the anchor bolt (see Figure 9, Figure 10), therefore:
 - LF11: Loosen the set screw M4 (1). Using a cylindrical tool (2) (diameter 2mm) turn the anchor bolt (3) in the appropriate direction.
 - LF9: Loosen socket screw (2.5 mm). Turn the anchor screw (3) with your hand into the corresponding direction.
2. The air-gap between magnetic coil (4) and anchor screw (3) is to be adjusted by means of a feeder gauge (5) according to Table 1: Technical data (see Figure 11)

If the magnetic coil and the anchor bolt clash together, then **the air gap is too small.**

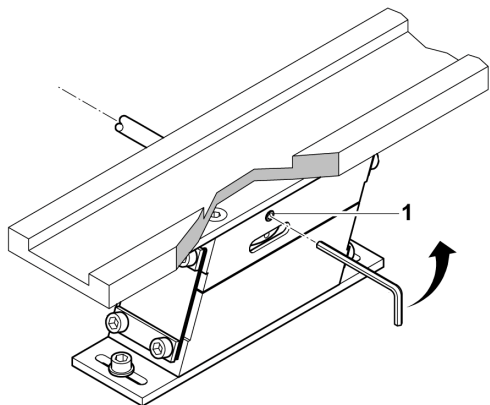

Figure 9

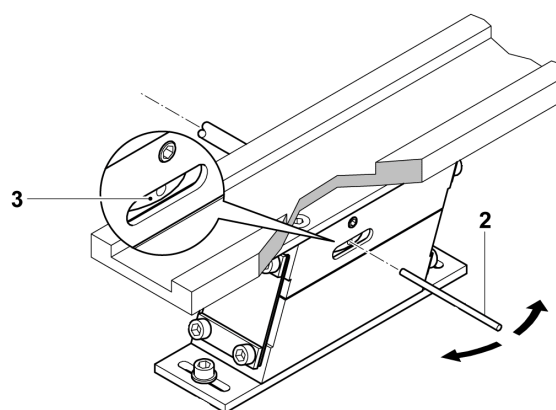

Figure 10

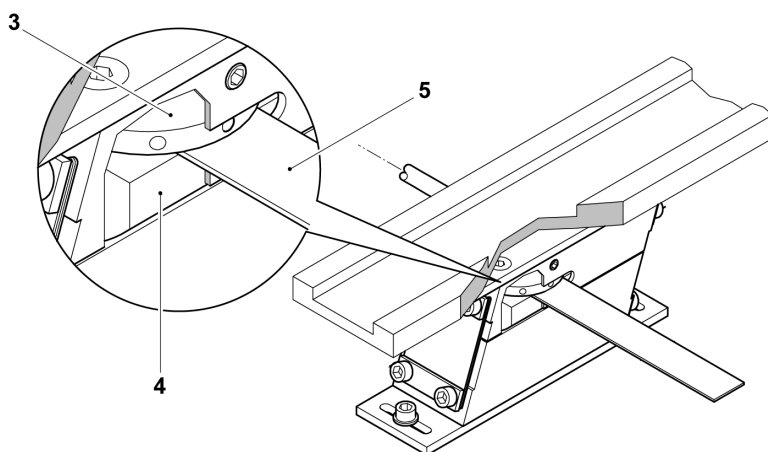

Figure 11

6.5 Spare and wearing parts

Table 2: *Wear parts*

Type	Pos.	Designation	Order number
LF 9	4	Leaf spring 0,7mm	15184920
LF 11		Leaf spring 0,5mm	11006743

Table 3: Spare parts

Type	Pos.	Designation	Power Supply	Order number
LF 9	6	Magnet	230V/50Hz	15022352
			115V/60Hz	15031879
LF 11	6	Magnet	230V/50Hz	11006386
	15	Lock pin	-	11006752

7 Accessories

7.1 Mounting parts

Table 4: Accessories mounting parts

Type	Index	Designation	Order number
LF 9	4	Mounting plate	50037641
LF 11		Mounting plate	11006745

7.2 Control device

The LF is connected to the 230/50Hz AC network via the control device of type IRG or SE. The device can be made compatible for other supply voltages and frequencies, e.g. 115V/60Hz. The linear feeder operates in full wave mode with the double power frequency, i.e. at 50Hz AC with a mechanical 100 Hz vibration frequency. Due to the change of the magnetic fluxes and thus the magnetic forces, the vibration displacement and thus the conveyor speeds are infinitely variable. Soft starting, all IRG and SE types offer different ways for the setup and mounting as well as the activation. For a detailed description of the control devices, please refer to the AFAG general catalogue. Non-OEM control devices can also be used for as long as they meet the technical requirements.

Table 5: Accessories control devices

Type	Power supply	Order number	Comment
IRG1-N	230V / 50Hz	15083186	Activation without timer function
	115V / 60Hz	15171112	
IRG2-N	230V / 50Hz	15204235	Activation with timer function via sensors
	115V / 60Hz	15182634	
SE601	230V / 50Hz	11015601	Sensor input, timer function, valve and interface outputs
	115V / 60Hz	50018668	
SE602	230V / 50Hz	11015602	Sensor input
	115V / 60Hz	50018674	

7.3 Address for orders

Germany:

Afag GmbH
Wernher-von-Braun-Straße 5a
D – 92224 Amberg
Tel.: ++49 (0) 96 21 / 65 0 27-0
Fax: ++49 (0) 96 21 / 65 0 27-390

Sales

Afag GmbH
Berliner Straße 31
D – 71229 Leonberg
Tel.: ++49 (0) 71 52 / 60 08-0
Fax. ++49 (0) 71 52 / 60 08-10

sales@afag.com

www.afag.com

Switzerland:

Afag Automation AG
Zuführtechnik
Fiechtenstrasse32
CH – 4950 Huttwil
Tel.: ++41 (0) 62 / 959 86 86
Fax: ++41 (0) 62 / 959 87 87

8 Disposal

LF feeders that are no longer in use should not be disposed of as complete units but dismantled into separate materials and recycled. Non-recyclable components must be disposed of correctly.