

Module controller SE-Power

Mounting Instructions

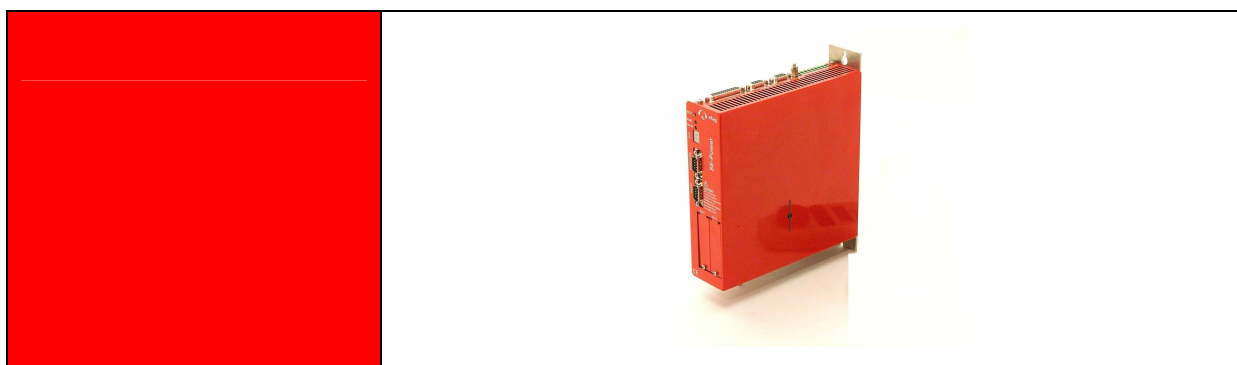

Index:

1	General.....	3
1.1	Documentation.....	3
2	Safety notes for electrical drives and controllers.....	4
2.1	Used symbols	4
2.2	General notes	4
2.3	Danger resulting from misuse	5
2.4	Safety notes.....	6
3	Technical data	12
4	Mechanical installation.....	17
4.1	Important notes.....	17
4.2	Mounting.....	21
4.3	Pin configuration [X1].....	23
4.4	Pin configuration Safe Standstill [X3].....	24
4.5	Pin configuration CAN [X4]	24
4.6	Pin connector Motor [X6] and Supply Power [X9].....	25
4.7	Pin configuration Incremental Encoder Input [X10].....	27
4.8	Pin configuration Incremental Encoder Output [X11]	28
5	EMC-compliant cabling.....	30
5.1	Operation with long motor cables	31

Tabel of figures:

Figure 1:	Servo positioning controller SE-POWER: Front view.....	18
Figure 2:	Servo positioning controller SE-POWER: Installation space	19
Figure 3:	Servo positioning controller SE-POWER: Bottom view.....	20
Figure 4:	Servo positioning controller SE-POWER: Top view.....	20
Figure 5:	Servo positioning controller SE-POWER: Mounting plateElectrical installation.....	22
Figure 6:	Connection to power supply [X9] and motor [X6].....	25

1 General

1.1 Documentation

This installation information serves the purpose of a safe use of the SE-POWER series servo positioning controller. It contains safety notes, which must be complied with.

Further information can be found in the following electronic manuals of the SE-POWER product range:

- **SE-Power Product Manual:** Description of technical specifications and device functionality as well as notes on installation and operation of the servo positioning controller SE-POWER.
- **SE-Power Software:** Description of device functionality and software functions of the firmware including RS232 communication. Description of parameterisation software Afag SE-Commander with instructions on the commissioning of an SE-POWER series servo positioning controller.
- **SE-Power CAN Manual:** Description of the implemented CANopen protocol as per DSP402.
- **SE-Power Profibus Handbuch:** Description of the implemented PROFIBUS-DP protocol.

2 Safety notes for electrical drives and controllers

2.1 Used symbols



Information
Important information and notes.



Caution!
Nonobservance may result in severe property damages.



DANGER!
Nonobservance may result in **property damages** and in **personal injuries**.



Caution! Dangerous voltages.
The safety note indicates a possible perilous voltage.

2.2 General notes

In the case of damage resulting from non-compliance of the safety notes in this manual Afag will refuse any liability.







Sound and safe operation of the servo drive controller requires proper and professional transportation, storage, assembly and installation as well as proper operation and maintenance. Only trained and qualified personnel may handle electrical devices:

TRAINED AND QUALIFIED PERSONNEL

in the sense of this product manual or the safety notes on the product itself are persons who are sufficiently familiar with the setup, assembly, commissioning and operation of the product as well as all warnings and precautions as per the instructions in this manual and who are sufficiently qualified in their field of expertise:

- Education and instruction or authorisation to switch devices/systems on and off and to ground them as per the standards of safety engineering and to efficiently label them as per the job demands.
- Education and instruction as per the standards of safety engineering regarding the maintenance and use of adequate safety equipment.
- First aid training.

The following notes must be read prior to the initial operation of the system to prevent personal injuries and/or property damages:

-  These safety notes must be complied with at all times.
-  Do not try to install or commission the servo drive controller before carefully reading all safety notes for electrical drives and controllers contained in this document. These safety instructions and all other user notes must be read prior to any work with the servo drive controller.
-  In case you do not have any user notes for the servo drive controller, please contact your sales representative. Immediately demand these documents to be sent to the person responsible for the safe operation of the servo drive controller.
-  If you sell, rent and/or otherwise make this device available to others, these safety notes must also be included.
-  The user must not open the servo drive controller for safety and warranty reasons.
-  Professional control process design is a prerequisite for sound functioning of the servo drive controller!



DANGER!

Inappropriate handling of the servo drive controller and non-compliance of the warnings as well as inappropriate intervention in the safety features may result in property damage, personal injuries, electric shock or in extreme cases even death.

2.3 Danger resulting from misuse



DANGER!

High electrical voltages and high load currents!
Danger to life or serious personal injury from electrical shock!



DANGER!

High electrical voltage caused by wrong connections!
Danger to life or serious personal injury from electrical shock!

**DANGER!**

Surfaces of device housing may be hot!
Risk of injury! Risk of burning!

**DANGER!****Dangerous movements!**

Danger to life, serious personal injury or property damage due to unintentional movements of the motors!

2.4 Safety notes

2.4.1 General safety notes



The servo drive controller corresponds to IP20 class of protection as well as pollution level 1. Make sure that the environment corresponds to this class of protection and pollution level.



Only use replacements parts and accessories approved by the manufacturer.



The devices must be connected to the mains supply as per EN regulations, so that they can be cut off the mains supply by means of corresponding separation devices (e.g. main switch, contactor, power switch).



The servo drive controller may be protected using an AC/DC sensitive 300mA fault current protection switch (RCD = Residual Current protective Device).



Gold contacts or contacts with a high contact pressure should be used to switch the control contacts.



Preventive interference rejection measures should be taken for control panels, such as connecting contactors and relays using RC elements or diodes.



The safety rules and regulations of the country in which the device will be operated must be complied with.



The environment conditions defined in the product documentation must be kept. Safety-critical applications are not allowed, unless specifically approved by the manufacturer.



The compliance with the limits required by national regulations is the responsibility of the manufacturer of the machine or system.



The technical data and the connection and installation conditions for the servo drive controller are to be found in this product manual and must be met.



DANGER!

The general setup and safety regulations for work on power installations (e.g. DIN, VDE, EN, IEC or other national and international regulations) must be complied with.

Non-compliance may result in death, personal injury or serious property damages.



Without claiming completeness, the following regulations and others apply:

VDE 0100 Regulations for the installation of high voltage (up to 1000 V) devices

EN 60204 Electrical equipment of machines

EN 50178 Electronic equipment for use in power installations

2.4.2 Safety notes for assembly and maintenance

The appropriate DIN, VDE, EN and IEC regulations as well as all national and local safety regulations and rules for the prevention of accidents apply for the assembly and maintenance of the system. The plant engineer or the operator is responsible for compliance with these regulations:



The servo drive controller must only be operated, maintained and/or repaired by personnel trained and qualified for working on or with electrical devices.

Prevention of accidents, injuries and/or damages:



Additionally secure vertical axes against falling down or lowering after the motor has been switched off, e.g. by means of:

- Mechanical locking of the vertical axle,
- External braking, catching or clamping devices or
- Sufficient balancing of the axle.



The motor holding brake supplied by default or an external motor holding brake driven by the drive controller alone is not suitable for personal protection!



Render the electrical equipment voltage-free using the main switch and protect it from being switched on again until the DC bus circuit is discharged, in the case of:

- Maintenance and repair work
- Cleaning
- long machine shutdowns



Prior to carrying out maintenance work make sure that the power supply has been turned off, locked and the DC bus circuit is discharged.



The external or internal brake resistor carries dangerous DC bus voltages during operation of the servo drive controller and up to 5 minutes thereafter. Contact may result in death or serious personal injury.



Be careful during the assembly. During the assembly and also later during operation of the drive, make sure to prevent drill chips, metal dust or assembly parts (screws, nuts, cable sections) from falling into the device.



Also make sure that the external power supply of the controller (24V) is switched off.



The DC bus circuit or the mains supply must always be switched off prior to switching off the 24V controller supply.



Carry out work in the machine area only, if AC and/or DC supplies are switched off. Switched off output stages or controller enablings are no suitable means of locking. In the case of a malfunction the drive may accidentally be put into action.



Initial operation must be carried out with idle motors, to prevent mechanical damages e.g. due to the wrong direction of rotation.



Electronic devices are never fail-safe. It is the user's responsibility, in the case an electrical device fails, to make sure the system is transferred into a secure state.



The servo drive controller and in particular the brake resistor, externally or internally, can assume high temperatures, which may cause serious burns.

2.4.3 Protection against contact with electrical parts

This section only concerns devices and drive components carrying voltages exceeding 50 V. Contact with parts carrying voltages of more than 50 V can be dangerous for people and may cause electrical shock. During operation of electrical devices some parts of these devices will inevitably carry dangerous voltages.



DANGER!

High electrical voltage!

Danger to life, danger due to electrical shock or serious personal injury!

The appropriate DIN, VDE, EN and IEC regulations as well as all national and local safety regulations and rules for the prevention of accidents apply for the assembly and maintenance of the system. The plant engineer or the operator is responsible for compliance with these regulations:



Before switching on the device, install the appropriate covers and protections against accidental contact. Rack-mounted devices must be protected against accidental contact by means of a housing, e.g. a switch cabinet. The regulations VGB4 must be complied with!



Always connect the ground conductor of the electrical equipment and devices securely to the mains supply. Due to the integrated line filter the leakage current exceeds 3.5 mA!



Comply with the minimum copper cross-section for the ground conductor over its entire length as per EN60617!



Prior to the initial operation, even for short measuring or testing purposes, always connect the ground conductor of all electrical devices as per the terminal diagram or connect it to the ground wire. Otherwise the housing may carry high voltages which can cause electrical shock.



Do not touch electrical connections of the components when switched on.



Prior to accessing electrical parts carrying voltages exceeding 50 Volts, disconnect the device from the mains or power supply. Protect it from being switched on again.



For the installation the amount of DC bus voltage must be considered, particularly regarding insulation and protective measures. Ensure proper grounding, wire dimensioning and corresponding short-circuit protection.



The device comprises a rapid discharge circuit for the DC bus as per EN60204 section 6.2.4. In certain device constellations, however, mostly in the case of parallel connection of several servo drive controllers in the DC bus or in the case of an unconnected brake resistor, this rapid discharge may be rendered ineffective. The servo drive controllers can carry voltage until up to 5 minutes after being switched off (residual capacitor charge).

2.4.4 Protection against electrical shock by means of protective extra-low voltage (PELV)

All connections and terminals with voltages between 5 and 50 Volts at the servo drive controller are protective extra-low voltage, which are designed safe from contact in correspondence with the following standards:

International: IEC 60364-4-41

European countries within the EU: EN 50178/1998, section 5.2.8.1.



DANGER!

High electrical voltages due to wrong connections!

Danger to life, risk of injury due to electrical shock!

Only devices and electrical components and wires with a protective extra low voltage (PELV) may be connected to connectors and terminals with voltages between 0 to 50 Volts.

Only connect voltages and circuits with protection against dangerous voltages. Such protection may be achieved by means of isolation transformers, safe optocouplers or battery operation.

2.4.5 Protection against dangerous movements

Dangerous movements can be caused by faulty control of connected motors, for different reasons:

- Improper or faulty wiring or cabling
- Error in handling of components
- Error in sensor or transducer
- Defective or non-EMC-compliant components
- Error in software in superordinated control system

These errors can occur directly after switching on the device or after an indeterminate time of operation.

The monitors in the drive components for the most part rule out malfunctions in the connected drives. In view of personal protection, particularly the danger of personal injury and/or property damage, this may not be relied on exclusively. Until the built-in monitors come into effect, faulty drive movements must be taken into account; their magnitude depends on the type of control and on the operating state.



DANGER!

Dangerous movements!

Danger to life, risk of injury, serious personal injuries or property damage!

For the reasons mentioned above, personal protection must be ensured by means of monitoring or superordinated measures on the device. These are installed in accordance with the specific data of the system and a danger and error analysis by the manufacturer. The safety regulations applying to the system are also taken into consideration. Random movements or other malfunctions may be caused by switching the safety installations off, by bypassing them or by not activating them. Protection against contact with hot parts



DANGER!

Housing surfaces may be hot!

Risk of injury! Risk of burning!



Do not touch housing surfaces in the vicinity of heat sources! Danger of burning!



Before accessing devices let them cool down for 10 minutes after switching them off.



Touching hot parts of the equipment such as the housing, which contain heat sinks and resistors, may cause burns!

2.4.6 Protection during handling and assembly

Handling and assembly of certain parts and components in an unsuitable manner may under adverse conditions cause injuries.



DANGER!

Risk of injury due to improper handling!

Personal injury due to pinching, shearing, cutting, crushing!

The following general safety notes apply:



Comply with the general setup and safety regulations on handling and assembly.



Use suitable assembly and transportation devices.



Prevent incarcerations and contusions by means of suitable protective measures.



Use suitable tools only. If specified, use special tools.



Use lifting devices and tools appropriately.



If necessary, use suitable protective equipment (e.g. goggles, protective footwear, protective gloves).



Do not stand underneath hanging loads.



Remove leaking liquids on the floor immediately to prevent slipping.

3 Technical data

Range	SE-POWER	
Ambient conditions and qualification:		
Admissible temperature ranges	Storage temperature:	-25°C to +70°C
	Operating temperature:	0°C to +40°C +40°C to +50°C at reduced power 2,5%/K
Admissible installation height	Up to 1000 m above msl, 1000 to 4000 m above msl at reduced power	
Humidity	Relative humidity up to 90%, not bedewing	
Protection class	IP20	
Pollution degree	1	
CE conformity Low-voltage directive: EMC regulation: Current harmonics:	EN 50 178 EN 61 800 – 3 EN 61 000 – 3 – 2	
Certifications	UL in preparation	

Dimensions and weight:	
Dimensions: H*W*D	225*54,5*200 mm
Dimensions of the mounting plate	240*48,5 mm
Weight	2,1 kg

Performance data [X9]:	
Supply voltage	1 x 100 .. 230 VAC [± 10%]
Alternative DC supply	60 .. 380 VDC
24V supply *) plus current consumption of a possibly connected holding brake and I/Os	24 VDC [± 20%] (0,65 A) *)

Performance data [X9]:	
Intermediate circuit voltage with active PFC (load-dependent)	360 .. 380 VDC

Internal brake resistor [X9]:	
Brake resistance internal	110 Ω
Pulse power	1,6 kW
Continuous power	20 W
Threshold limit	420..440 V
Output power	1,0 kVA
Max. output power for 5 s	2,0 kVA
Output current	5 A _{RMS}
Max. output current for 5 s	10 A _{RMS}
Clock frequency	max. 13 kHz
Max. mains current for continuous operation	4,7 A _{RMS}
Brake resistance external	$\geq 80 \Omega$
Continuous power	$\leq 500 W$
Operating voltage	$\geq 460 V$
Continuous power output	1000 W
Peak power output	2000 W

Maximum motor cable length for interference emission as per EN 61800-3 (corresponds to EN 55011, EN 55022):	
First ambient Switch cabinet assembly (residential area)	$l \leq 10m$
Second ambient (industrial area)	$l \leq 25m$
Cable capacity of a phase against shield or between two lines	$C' \leq 200pF/m$

Motor temperature monitoring:	
Digitaler sensor	Normally closed contact: $R_{hot} > 100 \text{ k}\Omega$
Analoger sensor	Silicon temperature sensor, e.g. KTY81, 82 or similar $R_{100} \approx 1700 \text{ }\Omega \dots 3400 \text{ }\Omega$

Resolver [X2A]:	
Resolution	16 Bit
Delay time signal detection	< 200 μs
Speed resolution	ca. 4 min^{-1}
Absolute accuracy of angle detection	< 5'
Max. rotational speed	16.000 min^{-1}

Encoder evaluation [X2B]:	
Parameterisable number of encoder lines	1 - 16384 lines/rev.
Angular resolution / Interpolation	10 Bit / period
Encoder signals A, B	1 V_{PP} differential; 2.5 V offset
Encoder signal N	0.2 to 1 V_{PP} differential; 2.5 V offset
Commutation track A1, B1 (optional)	1 V_{PP} differential; 2.5 V offset
Input impedance encoder signals	Differential input 120 Ω
Limit frequency	$f_{Limit} > 400 \text{ kHz}$ (high-res. signal) $f_{Limit} \text{ ca. } 10 \text{ kHz}$ (commutation track)
Output supply	5 V or 12 V; max. 300 mA; currentlimited control via sensor lines Setpoint programmable via software

Digital inputs and outputs [X1]:	
Signal level	24V (8V...30V) active high, conforming with EN 1131-2

Logic inputs general	
DIN0	Bit 0 \
DIN1	Bit 1, \ Target selection for positioning
DIN2	Bit 2, / 16 targets selectable from target table
DIN3	Bit 3 /
DIN4	Control input stage enable at High
DIN5	Controller enable at High, clear error high-low transition at Low
DIN6	End switch input 0
DIN7	End switch input 1
DIN8	Homing switch
DIN9	Control signal Start positioning
DIN AIN1	Start homing
DIN AIN2	Set-up mode
Logic outputs general	Galvanically separated, 24V (8V...30V) active high
DOUT0	Servo controller operational 24 V, max. 100 mA
DOUT1	Homing active 24 V, max. 100 mA
DOUT2	In position 24 V, max. 100 mA
DOUT3	Remaining distance 24 V, max. 100 mA
DOUT4 (X6)	Holding brake 24 V, max. 1 A

Analog inputs and outputs [X1]:	
High-resolution analog input: AIN0	$\pm 10V$ input range, 16 Bit, differentially, < 250 μ s delay time
Analog input: AIN1	Optionally, this input can also be parameterized as digital input DIN AIN1 with a switching threshold at 8V. $\pm 10V$, 10 Bit, single ended, < 250 μ s delay time
Analog input: AIN2	Optionally, this input can also be parameterized as digital input DIN AIN2 with a switching threshold at 8V. $\pm 10V$, 10 Bit, single ended, < 250 μ s delay time
Analog outputs: AOUT0 and AOUT1	$\pm 10V$ output range, 9 bit resolution, $f_{Limit} > 1kHz$

Incremental encoder input [X10]:

Trace signals	As per RS422 specification
Max. input frequency	500 kHz
Pulse-direction interface	As per RS422 specification

Incremental encoder output [X11]:	
Number of lines	Programmable 1 – 16384 lines/rev.
Connection level	Differential / RS422 specification
Encoder signals A, B, N	As per RS422 specification
speciality	N-Trace disconnectible
Output impedance	$R_{a,diff} = 66 \Omega$
Limit frequency	$f_{Limit} > 1,8 \text{ MHz (lines/s)}$
Edge triggering (minimum pulse width)	Can be limited by parameters
Output supply	5 V, max. 100 mA

4 Mechanical installation

4.1 Important notes

- Only use the servo positioning controller SE-POWER as a built-in device for power cabinets
- Mounting position vertical with supply lines [X9] on top
- Mount to control cabinet plate using a fastening strap
- Installation spaces: Keep a minimum distance of 100 mm to other components each above and underneath the device to ensure sufficient venting.
- The servo positioning controller SE-POWER may be installed adjacently in one switch cabinet without a gap, proper usage and installation on a heat-dissipating rear panel provided. Please note that excessive heat may cause premature aging and/or damaging of the device. In case the servo positioning controller SE-POWER are subject to high thermal stress, a space of 59 mm is recommended!

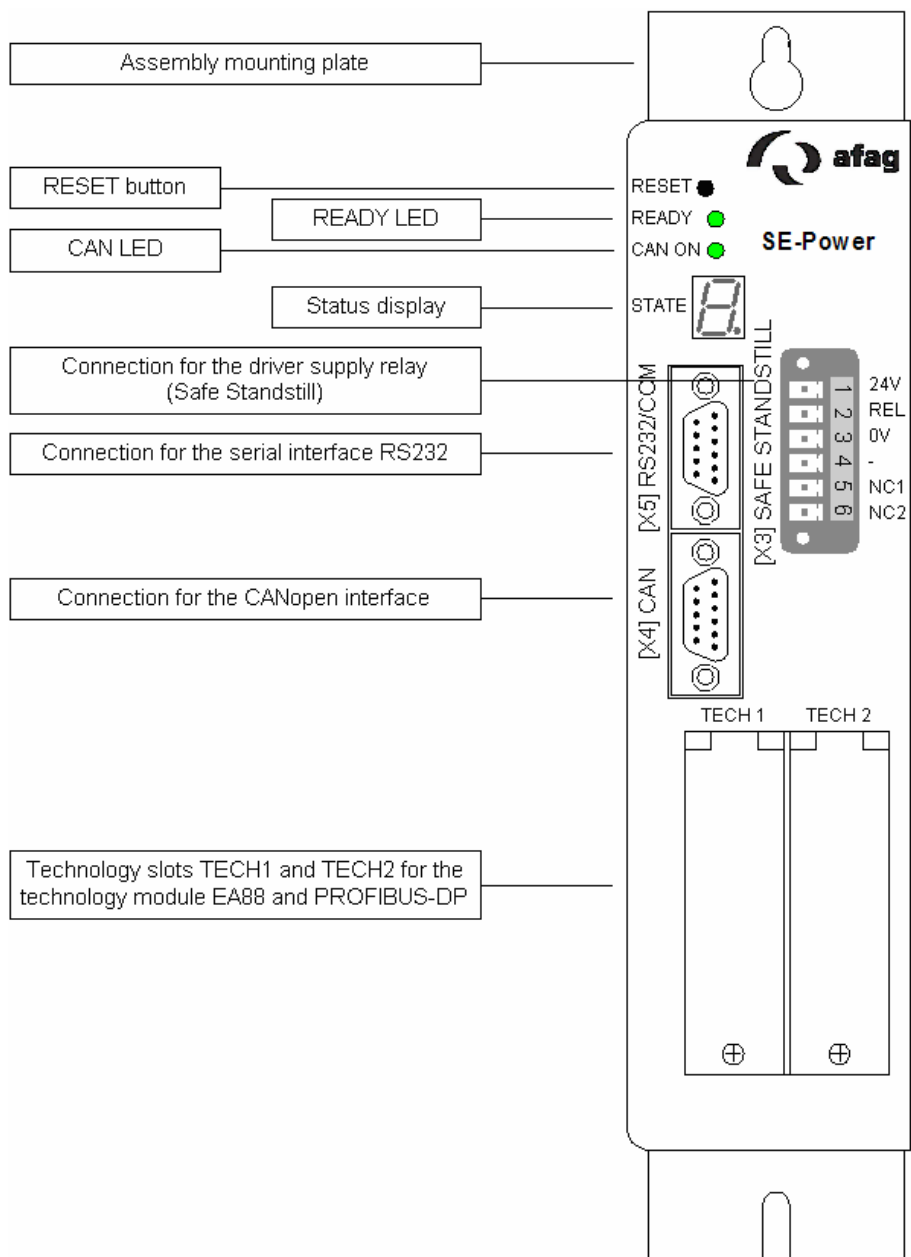

Figure 1: Servo positioning controller SE-POWER: Front view

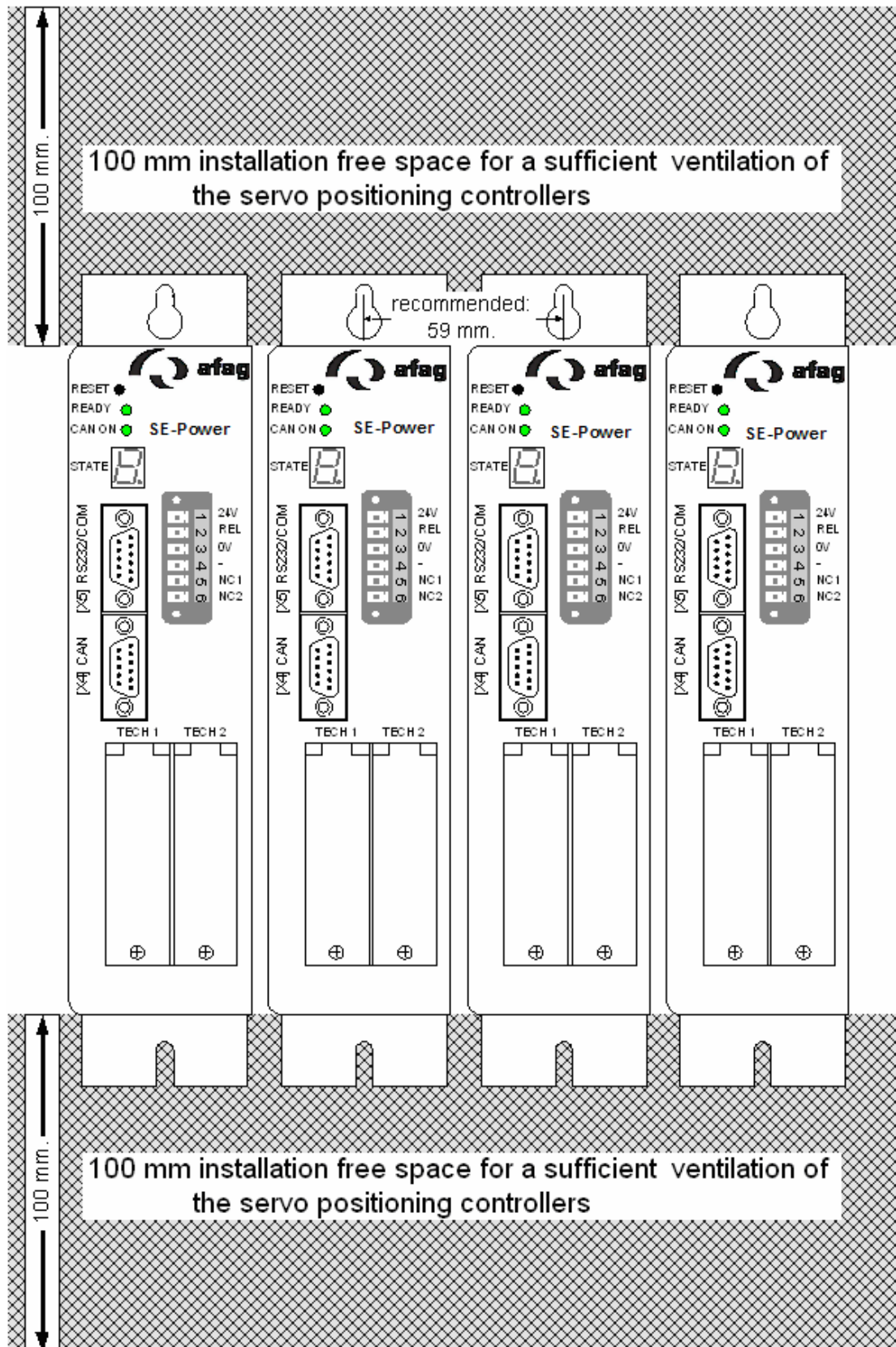

Figure 2: Servo positioning controller SE-POWER: Installation space

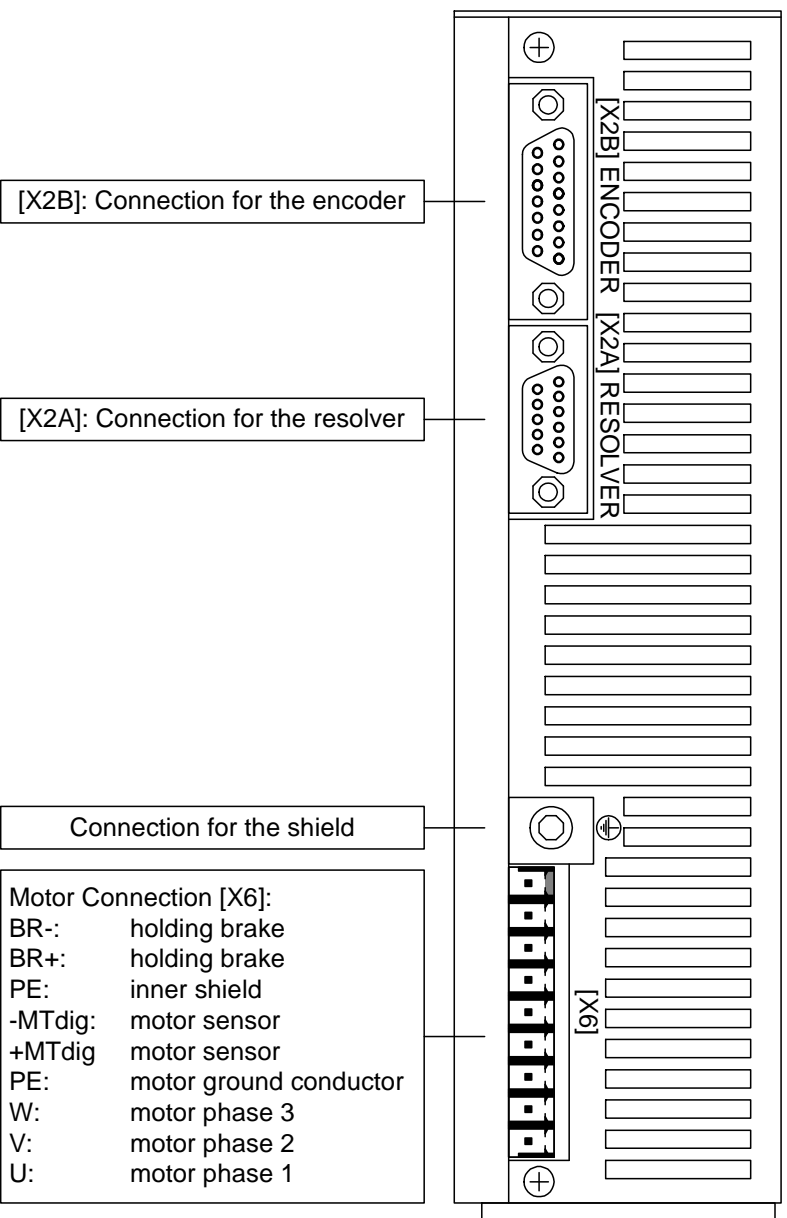

Figure 3: Servo positioning controller SE-POWER: Bottom view

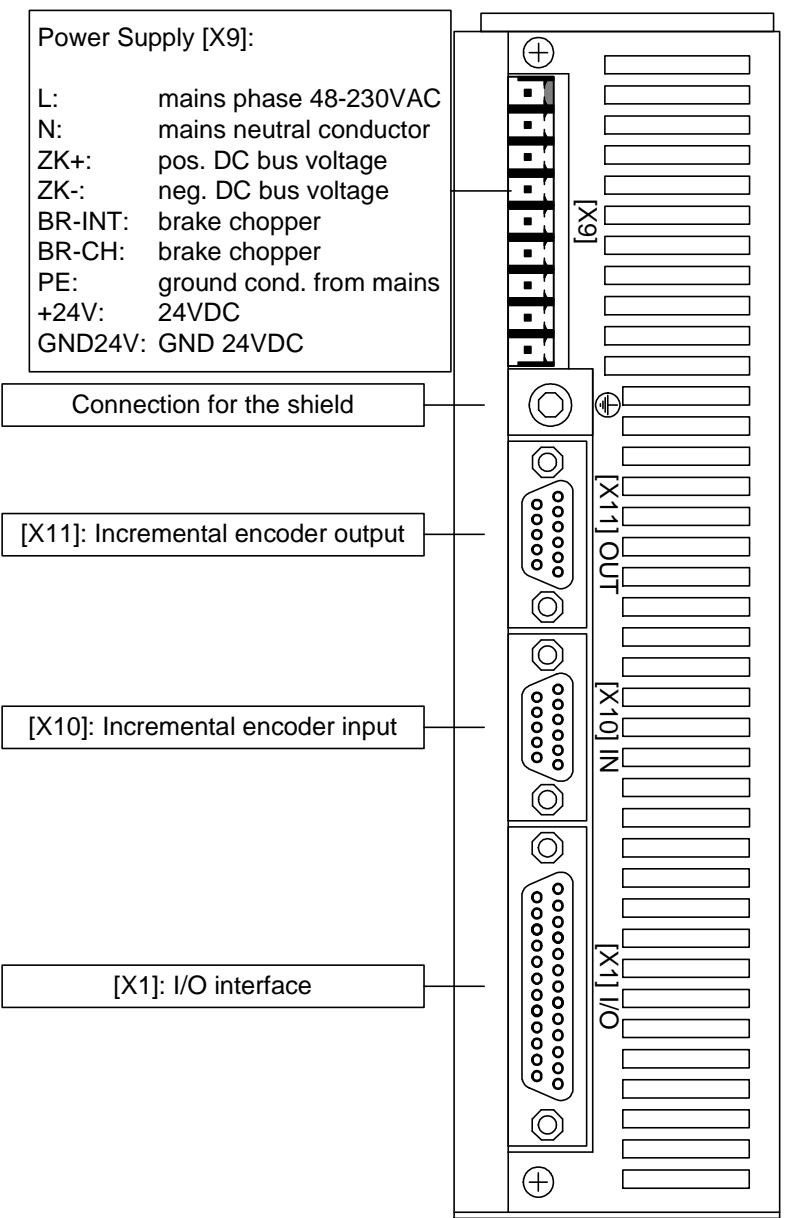

Figure 4: Servo positioning controller SE-POWER: Top view

4.2 Mounting

The servo positioning controller SE-POWER has attachment lugs on the top and the bottom of the device. These are used to mount the servo positioning controller vertically to a control cabinet plate. The lugs are part of the cooling body profile, thereby providing optimum heat transmission to the control cabinet plate.

Please use M5 screws for mounting of the servo positioning controller SE-POWER.

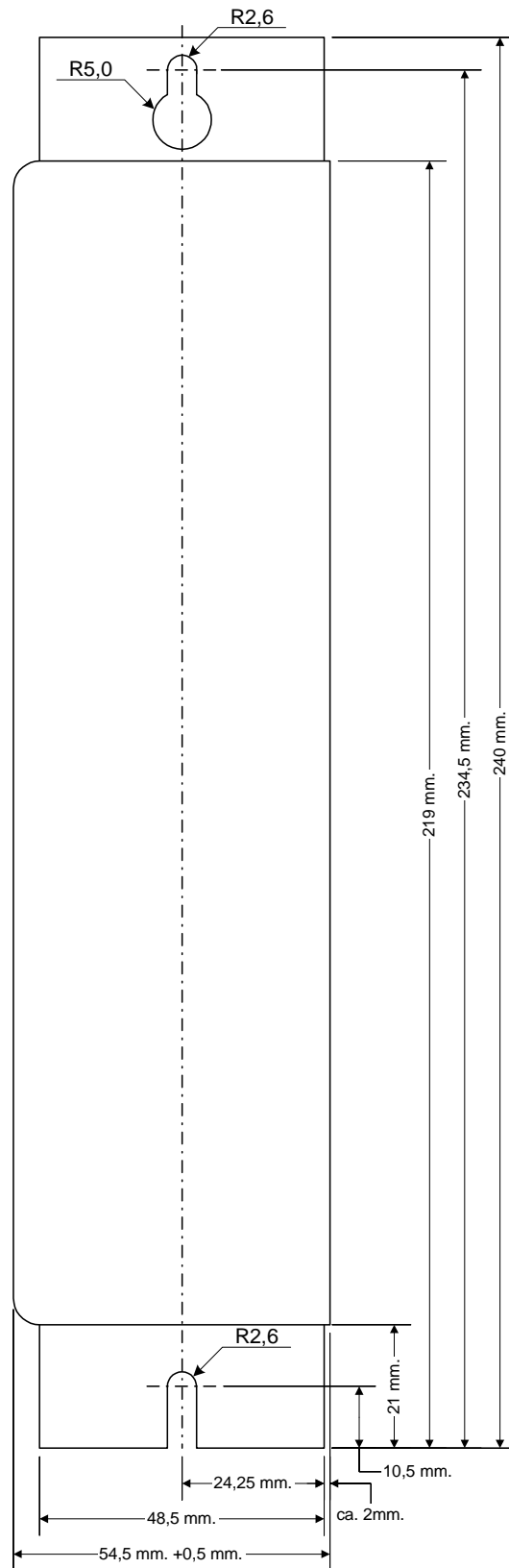

Figure 5: Servo positioning controller SE-POWER: Mounting plate Electrical installation

4.3 Pin configuration [X1]

Table 1: Connector configuration: I/O communication [X1]

Pin No.	Denomination	Value	Specification
1	AGND	0V	Shield for analog signals, AGND
14	AGND	0V	Reference potential for analog signals
2	AIn0	U _{on} = ±10V R ₁ =20kΩ	Setpoint input 0, differential, max. 30V input voltage
15	#AIn0		
3	DIN AIN1	Start_ref	Start homing
16	DIN AIN2	Set-up	Set – up mode
4	+VREF	+10V	Reference output for setpoint potentiometer
17	AMON0	±10V	Analog monitor output 0
5	AMON1	±10V	Analog monitor output 1
18	+24V	24V / 100mA	24V supply out
6	GND24	corresponding GND	Reference potential for digital I/Os
19	DIn0	POS Bit0	Target selection positioning Bit0
7	DIn1	POS Bit1	Target selection positioning Bit1
20	DIn2	POS Bit2	Target selection positioning Bit2
8	DIn3	POS Bit3	Target selection positioning Bit3
21	DIn4	FG_E	Power stage enable
9	DIn5	FG_R	Controller enable
22	DIn6	END0	Input end switch 0 (locks n > 0)
10	DIn7	END1	Input end switch 1 (locks n < 0)
23	DIn8	Ref	Homing switch
11	DIn9	START	Input for positioning start
24	DOut0 / READY	24V / 100mA	Servo controller operational
12	DOut1	24V / 100mA	Homing active
25	DOut2	24V / 100mA	In position
13	DOut3	24V / 100mA	Remaining distance



In the positioning mode the analog ground (PIN 14) must be connected to the ground of the 24 VDC supply voltage (PIN 6)!

4.4 Pin configuration Safe Standstill [X3]

Further information to the safety function is in the product manual SE-POWER in chapter 6 “Functional safety technology”.

Pin No.	Denomination	Value	Specification
1	24V	24VDC	24VDC supply, led out (Without safety measures in accordance with category 3: Bridge pin 1 and 2)
2	REL	0V / 24VDC	Setting and resetting of the relay for interrupting the driver supply of the output stage
3	0V	0V	Reference potential for PLC
4	n.c.		Not connected
5	NC1	250VAC max. switching voltage	Floating response contact of driver supply; normally closed contact
6	NC2		

4.5 Pin configuration CAN [X4]

Pin No.	Denomination	Value	Specification
1	-	-	Not occupied
6	GND	0V	CAN-GND, galvanically connected to DGND in controller
2	CANL	*)	CAN-Low signal line
7	CANH	*)	CAN-High signal line
3	GND	0V	See Pin no. 6
8	-	-	Not occupied
4	-	-	Not occupied
9	-	-	Not occupied
5	Cable shield	PE	Connection for cable shield

*) External terminating resistor 120Ω required on both ends of the bus

4.6 Pin connector Motor [X6] and Supply Power [X9]

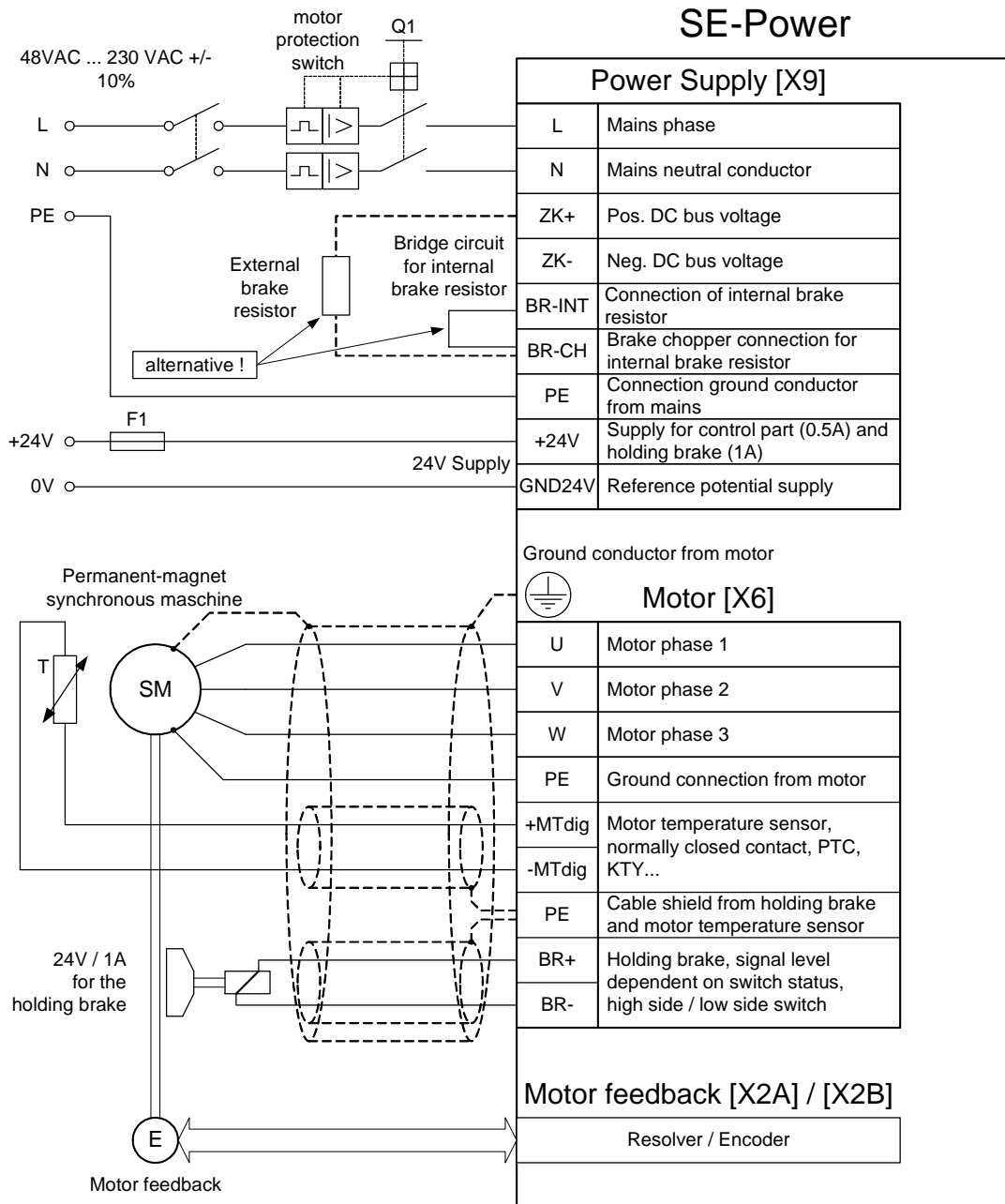
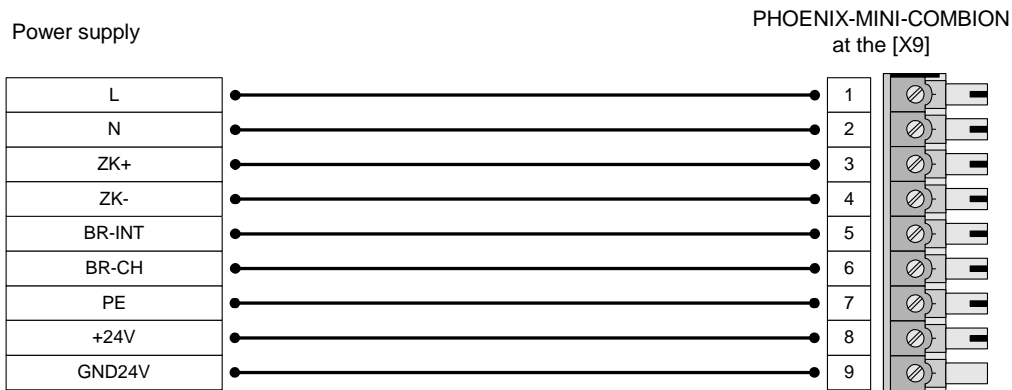
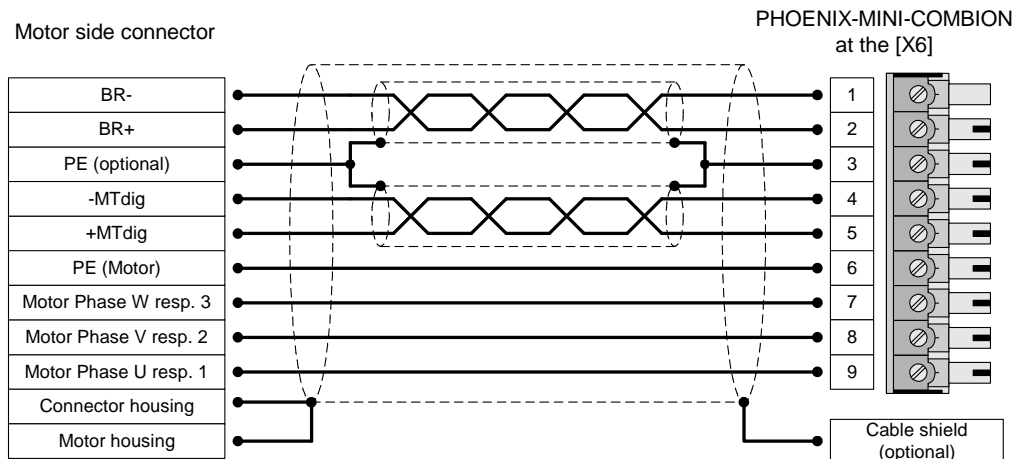

Figure 6: Connection to power supply [X9] and motor [X6]

The servo positioning controller SE-POWER is connected to the supply voltage, the motor, the brake resistor and the holding brakes as shown in Figure 5. The operation of the servo positioning controller SE-POWER requires a 24V supply source for the electronics, which is connected to the terminals +24V and GND24V. The connection to the supply for the power output stage is either made to terminals L1 and N for AC supply or to ZK+ and ZK- for DC supply.



The motor is connected to terminals U,V,W. The motor temperature switch (PTC or normally closed contact) is connected to terminals +Mtdig and –Mtdig, if it is lead into one cable together with the motor phases. If an analog temperature sensor (e.g. KTY81) is used in the motor, it is connected via the encoder cable to X2A or X2B.



- Connect the inner shields to PIN 3; maximum length 40 mm.
- Length of unshielded cores maximum 35 mm.
- Connect total shield on controller side flat to PE terminal; maximum length 40 mm.
- Connect total shield on motor side flat to connector or motor housing; maximum length 40 mm.



The cable shield of the motor cable must also be connected to the controller housing (PE screw terminal).

The connection of the shaft encoder via the D-Sub connector to X2A / X2B is roughly shown in Figure 5.

The servo positioning controller SE-POWER must be connected to ground with its PE connection.

The SE-POWER must be completely wired first. Only then may the operating voltages for the DC bus and the electronics supply be switched on. In the case of inversed wiring of the operating voltage connections, excessive operating voltage or in the case of confusing the connections for operating voltage and motor the servo positioning controller will be damaged.

4.7 Pin configuration Incremental Encoder Input [X10]

Pin No.	Denomination	Value	Specification
1	A / CLK	5V / $R_1 \approx 120\Omega$	Incremental encoder signal A / Stepper motor signal CLK pos. polarity as per RS422
6	#A / #CLK	5V / $R_1 \approx 120\Omega$	Incremental encoder signal A / Stepper motor signal CLK neg. polarity as per RS422
2	B / DIR	5V / $R_1 \approx 120\Omega$	Incremental encoder signal B / Stepper motor signal DIR pos. polarity as per RS422
7	#B / #DIR	5V / $R_1 \approx 120\Omega$	Incremental encoder signal B / Stepper motor signal DIR neg. polarity as per RS422
3	N	5V / $R_1 \approx 120\Omega$	Incremental encoder index pulse N pos. polarity as per RS422
8	#N	5V / $R_1 \approx 120\Omega$	Incremental encoder index pulse N neg. polarity as per RS422
4	GND	-	Supply GND for encoder
9	GND	-	Shield for the connection cable
5	VCC	+5V \pm 5% 100mA	Auxiliary supply, load with 100mA maximum, short circuit-proof

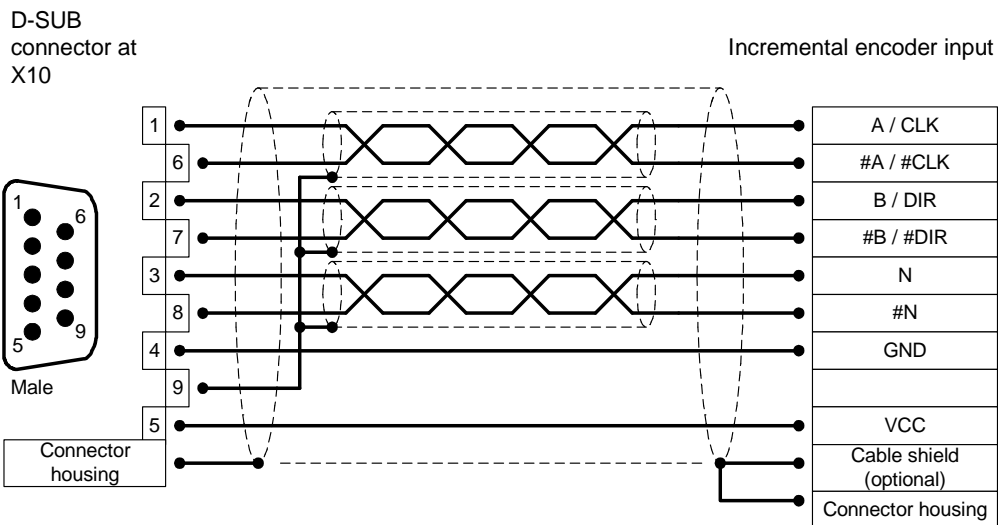

4.8 Pin configuration Incremental Encoder Output [X11]

Pin No.	Denomination	Value	Specification
1	A	5V / $R_A \approx 66\Omega$ *)	Incremental encoder signal A
6	#A	5V / $R_A \approx 66\Omega$ *)	Incremental encoder signal #A
2	B	5V / $R_A \approx 66\Omega$ *)	Incremental encoder signal B
7	#B	5V / $R_A \approx 66\Omega$ *)	Incremental encoder signal #B
3	N	5V / $R_A \approx 66\Omega$ *)	Incremental encoder index pulse N
8	#N	5V / $R_A \approx 66\Omega$ *)	Incremental encoder index pulse #N
4	GND	-	Reference GND for encoder
9	GND	-	Shield for connection cable
5	VCC	+5V $\pm 5\%$ 100mA	Auxiliary supply, to be loaded with maximal 100mA, short-circuit-proof

*) The value for R_A is the differential output resistance

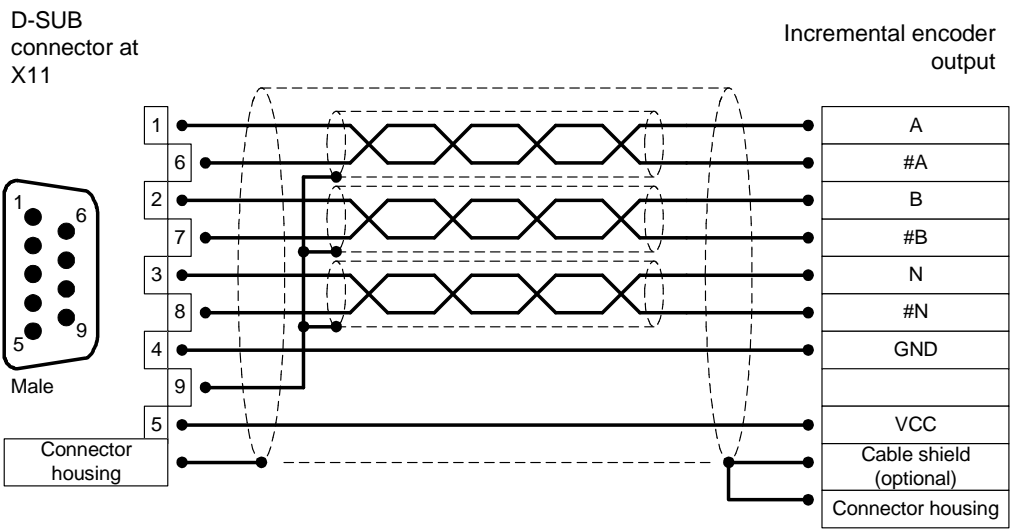

5 EMC-compliant cabling

The following must be considered for an EMC-compliant setup of the drive system:

- In the first environment, the servo positioning controller SE-POWER must be installed in a steel switch cabinet. In most cases a standard model will sufficiently attenuate emitted interference. The cable shields must be connected with the switch cabinet housing by means of metal cable glands.
- In the second environment the servo positioning controller SE-POWER can also be used without a steel control cabinet. Installation in a control cabinet (possibly plastic), however, is still necessary to guarantee proper usage.
- The control cabinet bed plate must be conducting (zinc-coated design). The imperative central grounding point should also be located on the control cabinet bed plate.
- The signal lines must be as far away from the power cables as possible. They should not be placed parallel. If intersections cannot be avoided, they should be perpendicular (i.e. at a 90° angle), if possible.
- In order to keep the leakage currents and the losses in the motor connection cable as small as possible, the servo positioning controller SE-POWER should be located as close to the motor as possible (see also the following chapter).
- The shield of the motor cable is connected to the housing of the servo positioning controller SE-POWER (shield connection terminal). In the first environment the shield of the motor cable also has to be connected to the control cabinet housing by means of metal cable glands.
- The mains-end PE connection is connected to the PE connection point of the supply connection [X9].
- The inner PE conductor of the motor cable is connected to the PE connection point of the motor connection [X6].
- Motor cable and angle encoder cable must be shielded.
- Unshielded signal and control lines should not be used. If their use is inevitable they should at least be twisted.
- Even shielded cables will inevitably have short unshielded ends (unless shielded connector housings are used). In general, the following applies:
 - Connect the inner shields to the corresponding pins of the connectors; Maximum length 40 mm.
 - Length of the unshielded cores 35 mm maximum.
 - Connect the total shield on the controller side flat to the PE terminal; Maximum length 40 mm.
 - Connect the total shield on the motor side flat to the connector housing or motor housing; Maximum length 40 mm.

**DANGER!**

For safety reasons, all PE ground conductors must be connected prior to initial operation.

The EN 50178 regulations for protective earthing must be complied with during installation!

5.1 Operation with long motor cables

In applications involving long motor cables and/or unsuitable motor cables with an inadvertently high cable capacity, the filters may be thermally overloaded. To avoid such problems we highly recommend the following procedure for applications that require long motor cables:

- With cable lengths of more than 25 m use only cables with a capacitance per unit length between the motor phase and the shield of less than 200pF/m, if possible less than 150pF/m! (Please contact the motor cable supplier, if necessary)
- Lower the power stage clock frequency when using cable lengths of 25 m or longer.

Both measures are also good for the EMC behavior of the entire drive:

The servo positioning controller generates less and less severe interference and the emission of interference into the mains is reduced.



Afag Automation AG

Fiechtenstrasse 32

4950 Huttwil

Schweiz

Tel.: +41 (0)62 – 959 86 86

Fax.: +41 (0)62 – 959 87 87

e-mail: sales@afag.com

Internet: www.afag.com